



Operating manual

HORNET

W 85 H INOX

Translation of the
original operating manual

Copyright

**Be certain to read this operation manual before commissioning the device.
No guarantee claim exists for malfunctions and damages to the device caused by
insufficient knowledge of the operation manual.**

© HORN GmbH & Co. KG. All rights reserved.

Text, graphics and layout copyright protected. Reproduction and copying, including in part, only permitted with written permission. Technical changes reserved.

Service Hotline +49 1805 900 301

(0.14 €/min. from the German landline network, cellular phone max. 0.42 €/min.)

service@tecalemite.de

Document Number: 44 1642 104-G
As of: March 20, 2014

Table of contents

1	Safety Instructions	5
2	Technical Description	7
	2.1 Description / Designated Use	7
	2.2 Product Variants	8
	2.3 Allowed Media.....	10
	2.4 Technical Information	10
3	Installation instructions	11
	3.1 Pump with standard IBC + drum bracket.....	11
	3.2 Pump with side IBC bracket.....	12
	3.3 Connecting the CDS dry coupling	13
	3.4 Drum Transfer Pump with Suction Tube.....	14
	3.5 Installation Site.....	15
	3.6 Note the Installation Location!.....	15
	3.7 Temperature.....	15
	3.8 Conveyance Capacity	15
	3.9 Electrical Connection.....	15
4	Commissioning / Operation	16
	4.1 Suction / Dry Running.....	16
	4.2 Tank Procedure	16
	4.3 Meter FMT II (optional)	16
5	Automatic pump nozzle A2003-ES	17
	5.1 Technical Deskription.....	17
	5.1.1 General Description.....	17
	5.1.2 Appropriate use.....	17
	5.1.3 Function / Safety equipment.....	18
	5.1.4 Technical data.....	18
	5.2 Requirements for the operating area	18
	5.3 Operating instructions	18
	5.3.1 Installation instructions/ Commissioning.....	18
	5.3.2 Operating instructions.....	19
	5.4 Maintenance.....	20
6	Flow Meter FMT II	21
	6.1 Technical Description FMT II.....	21
	6.1.1 Display	21
	6.1.2 Keyboard.....	21
	6.1.3 Battery.....	21
	6.1.4 Measured Value Recording	21
	6.2 Operation FMT II	21
	6.2.1 Delivery Condition.....	21
	6.2.2 Basic Condition, Flow Measurement.....	21
	6.2.3 Reset - "Reset" Button.....	21
	6.2.4 Totalizator - "Total" Button	22
	6.2.5 Display of the Calibration Factor - "Total" + "Reset" Buttons	22
7	Error Message - What to do, if...?	22
8	Maintenance	23
	8.1 Leak Test.....	23
	8.2 Cleaning the System	23

9	Replacement Parts	24
9.1	Replacement Parts Standard bracket.....	24
9.2	Replacement parts for side bracket	25
9.3	Replacement Parts Drum Transfer Pump	26
9.4	Instructions for Replacing the Pump Rotor.....	27
10	Disposal	27
10.1	Return of batteries	27
11	Scale Image of the HORNET W 85 H INOX	28
12	Declaration of Conformity	29

1 Safety Instructions

This device has been constructed per the current state of technology and in accordance with the recognized technical safety regulations. Regardless, risks to the user or third parties and/or damages to the device or other material assets could result from its use. The instructions in this operation manual, especially the safety instructions and the sections marked with warning signs, must thus be complied with.

Warning Signs and Symbols

The following symbols are used for especially important information in the operation manual.



Special information regarding the efficient use of the device.



Special information and/or dos and don'ts for damage prevention.



Information and/or dos and don'ts for personal accident prevention or comprehensive material damages.

Designated Use



This device may only be used when functioning free of technical problems and must be used according to its designated use, with full knowledge of the safety and hazard risks and in consideration of the instruction manual! Malfunctions which could affect safety must be remedied immediately.



The device and its components are to be used exclusively with the fluids listed and the use designated. Any other use or use extending beyond is deemed as undesignated. The manufacturer is not liable for damages thus resulting; the operator shall bear the risk alone.

Organizational Measures



The operation manual must always be kept accessible at the place of use! Every person who is involved with the assembly, commissioning, maintenance and operation of the device must have read and understood the complete operation manual. The type label on the device and the warning signs on the device must be heeded and kept in a fully legible condition.

Qualified Personnel

- ! The personnel for the operation, maintenance and assembly must have the corresponding qualifications for this work. The operator must precisely regulate the spheres of responsibility, authority and monitoring of the personnel. If the personnel do not possess the necessary knowledge, they must be trained and instructed. In addition, the operator must ensure that the contents of the operation manual have been fully understood by the personnel.

Water Protection

-  The device is designed to handle substances hazardous to water. The valid regulations for the place of use (e.g. water resources act, ordinance for systems with substances hazardous to water) are to be complied with.

Hydraulics

-  Only personnel with special knowledge and experience with hydraulics may work on the hydraulic parts and equipment. All wires, hoses and screws must be checked regularly for leaks and externally detectable damages and these must be remedied immediately.
Squirting oil can cause injuries and fires.
Note the safety guidelines valid for the product when dealing with oils, greases and other chemical substances!

Maintenance and Repairs

-  In accordance with the legal regulations, only companies specialized can be hired for work with systems for substances hazardous to water. Do not make any modification, additions or conversions to the system which could affect its safety with the approval of the manufacturer. Replacement parts must correspond to the technical requirements of the manufacturer. This is always ensured when original parts are used.

Only the manufacturer is permitted to make manipulations of any kind to the flow meter FMT II besides changing the batteries.

Electrical Energy

-  Work on the electrical equipment may only be conducted by a trained electrical technician or by trained personnel under the supervision of an electrical technician as per the electrical engineering regulations. Machines and system components which are to undergo inspection, maintenance and repair work must be rendered current-less. First check that these components are voltage-free, then ground and short circuit them, as well as insulate neighboring voltage-carrying components.

2 Technical Description

2.1 Description / Designated Use

Electric hybrid pump HORNET W 85 H INOX

The HORNET W 85 H INOX is a self priming electric pump.

The HORNET W 85 H INOX is intended for use in industries, factories, gas stations and similar facilities. It is intended for the conveying and discharge of urea AUS 32 in accordance with ISO 22241. The pump must be firmly installed on the IBC tank or container during operation.



The HORNET W 85 H INOX may not be operated with flammable and explosive fluids with a flame point below 55°C (hazard classes AI, AII and B). Fluids with a flame point above 55°C (hazard class A III) may not be pumped if they have been heated above their flame point.



The pump has no safety device to prevent automatic restarting after interruption of the power supply.

Flow Meter FMT II

The FMT II is a flow meter for flowing liquids using the measurement principle of a turbine wheel flow meter. It is suitable for use as a stationary meter or as a hose end meter. The optional pulse generator allows use within a fluid management system. The turbine wheel flow meter FMT II consists of a measurement chamber with a turbine wheel and a cover which contains the evaluation electronics as well as the display and keyboard. The turbine wheel is equipped with a pair of magnets which transmit the counting pulses during volume flow from a reed switch to the evaluation electronics.



The FMT II may not be operated with flammable and explosive liquids of hazard classes AI, AII and B. Fluids of hazard class A III may not be used if they are heated above their flame point.

2.2 Product Variants

The HORNET W 85 H INOX is available with a number of different mounting types:

- Without accessories for individual mounting
- Incl. Standard bracket and dry coupling for mounting on IBC tanks and 200l drums.
- Incl. Bracket and dry coupling for side mounting on IBC tanks.
- Incl. Suction pipe for mounting on 200l drums.

An optional FMT II turbine meter can be used to measure the amount dispensed.

A number of different nozzles are available. The range on offer depends on customer requirements and regional regulations:

- Stainless steel nozzle, with automatic shut-off, without catch
- Stainless steel nozzle, with automatic shut-off, with catch
- Plastic nozzle, without automatic shut-off, without catch

The power plug is available in a number of national variants.

The following table lists the versions available

Art no.	Mounting type				FMT II meter	Nozzle			Power plug		
	Without accessories	Standard bracket	Side bracket	Drum pump		Automatic nozzle (without catch)	Automatic nozzle (with catch)	Standard plastic nozzle	Germany Type E (CEE7/7)	Switzerland Type J (SEV1011)	United Kingdom Type G (BS1363)
108 600 000	x								x		
108 600 100		x				x			x		
108 600 110			x			x			x		
108 600 200		x					x		x		
108 600 210			x				x		x		
108 600 300		x						x	x		
108 600 310			x					x	x		
108 600 400				x		x			x		
108 600 500				x			x		x		
108 600 600				x				x	x		
108 601 100		x			x	x			x		
108 601 110			x		x	x			x		
108 601 200		x			x		x		x		
108 601 210			x		x		x		x		
108 601 400				x	x	x			x		
108 601 500				x	x		x		x		
108 611 200		x			x		x			x	
UK 108 600 000	x										x
UK 108 600 210			x				x				x
UK 108 600 300		x						x			x
UK 108 600 310			x					x			x
UK 108 600 500				x			x				x
UK 108 600 600				x				x			x
UK 108 601 100		x			x		x				x
UK 108 601 210			x		x		x				x
UK 108 601 500		x			x		x				x

2.3 Allowed Media

All variants of the HORNET W 85 H INOX pump can convey urea solution AUS 32 in accordance with ISO 22241 and water.



No other media may be conveyed!



Please note the safety data sheet of your medium.

2.4 Technical Information

HORNET W 85 H INOX

Motor	AC Motor	Output	0.55 kW
Rated Current	2.6A	Voltage	230 V / 50 Hz
Duty Cycle	100 %	Protection Class	IP 54
Pump Type	Hybrid Pump	Pump Volume	max. 48 l/min*
Conveyance Pressure	max. 2.5 bar*	Suction Height	max. 4m*
Dimensions (HxWxD)	261x206x116mm	Suction Ports	IG 3/4"
Environmental Temperature	-10°C to 40°C	Pressure Ports	IG 3/4"
Media Temperature	-7°C to 40°C		
Sound Pressure Level	max. 80 dB(A)	Weight	ca. 3.7 kg

*Viscosity and system-dependent

Flow Meter FMT II

Smallest Volume Flow Q_{\min}	5 l/min	Precision	+/- 1% according to calibration
Largest Volume Flow Q_{\max}	90 l/min	Thread Connection	2x G1" AG
Max. Operating Pressure Q_{\max}	4 bar	Nominal Diameter	21 mm
Viscosity Range	0.8 - 40 mPa s	Dimensions (w x h x d)	90x130x61 mm

3 Installation instructions

The W 85 H INOX is delivered in the following equipment variants:

- Incl. Standard bracket and dry coupling for mounting on IBC tanks and 200l drums.
- Incl. Bracket and dry coupling for side mounting on IBC tanks.
- Incl. Suction pipe for mounting on 200l drums.)

+ optional FMT II flow meter

3.1 Pump with standard IBC + drum bracket

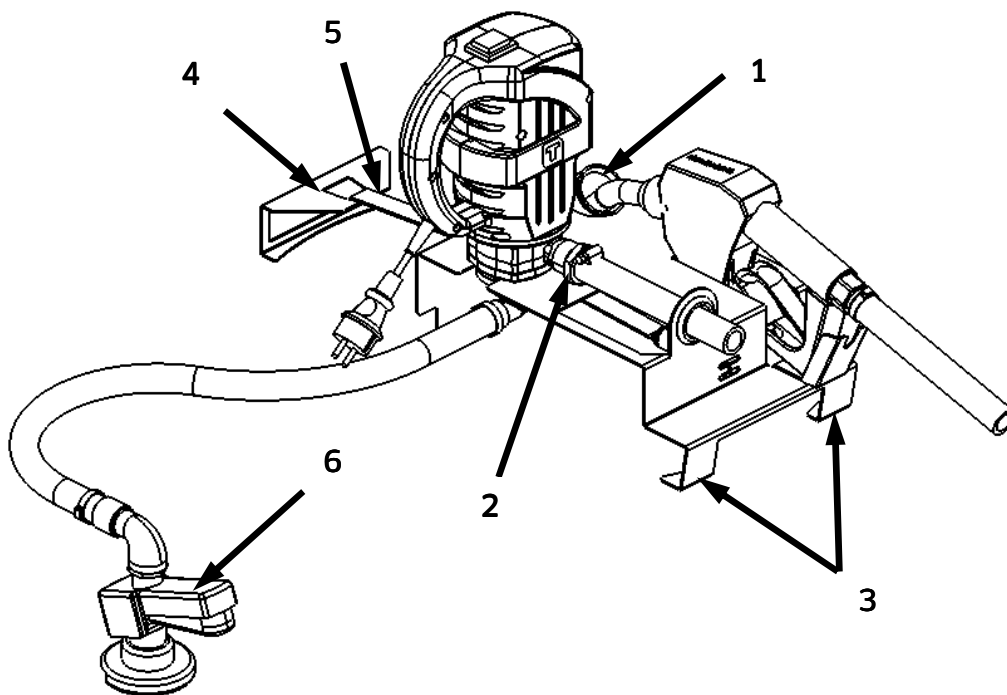

Insert the drip collection pipe (1) included in the scope of the delivery into the mounting hole on the bracket.

Screw the dispensation hose firmly onto the hose mandrel (2) on the dispensation side (remove sealing plug!) and insert the dispensing nozzle into the holder.

Place the bracket on the IBC cover plate or the top side of the drum such that the hooks (3) of the bracket hook onto the upper frame of the IBC tank or onto the underside of the bead of the drum.

Latch on the sheet metal hooks (4) on the opposite side and pull the strap (5) tight.

Connect the dry coupling to the suction line of the tank.

3.2 Pump with side IBC bracket

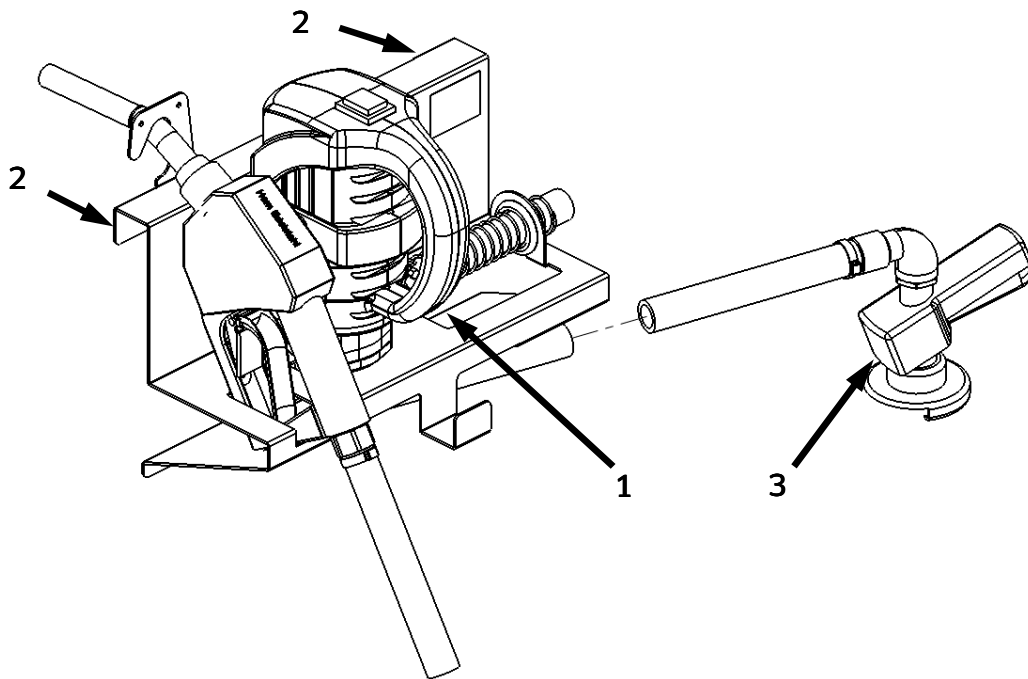

1. Screw the dispensation hose firmly onto the hose mandrel (1) on the dispensation side (remove sealing plug!) and insert the dispensing nozzle into the holder.
2. Hang the bracket on the side of the IBC such that the hooks (2) are securely latched onto the back of the circumferential frame of the IBC. (This bracket is not suitable for IBCs with a closed cover plate.)
3. Connect the dry coupling (3) with the suction line of the tank.

3.3 Connecting the CDS dry coupling

The variants with an IBC bracket are equipped with a CDS dry coupling with which the suction line of the pump is connected to the suction line in the IBC Tank or the drum. To connect the CDS coupling (3) to the IBC suction pipe (4), tighten the handle and place it onto the suction connector of the IBC. Release the handle to lock the adapter into place. (Please also refer to the diagram at the bottom of this page.) Ensure that the CDS coupling and the IBC suction pipe are clean and free of dirt.

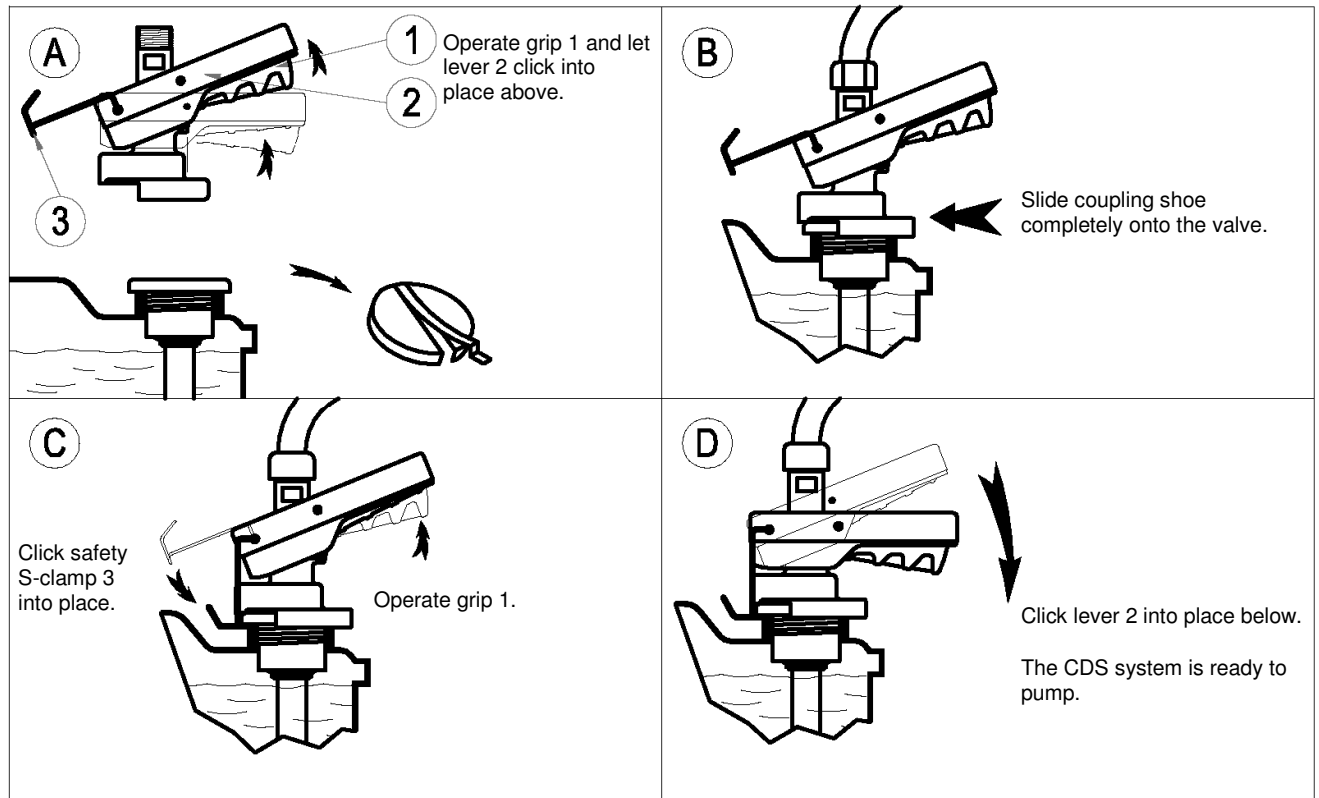

3.4 Drum Transfer Pump with Suction Tube

The drum pump versions are not equipped with a mounting bracket and a dry coupling for the suction side. They come with a stainless steel suction pipe that is inserted directly into the reservoir. The receptacle must have a 2" internal screw thread in order to attach the suction pipe. Adapters are available for receptacles with a buttress screw thread. The mounting is done as follows:

1. In order to suspend the nozzle valve, the nozzle valve holder (3) must first be placed on the pump chamber and attached with a 2" nut (4).
2. Place the drip tube (5) (included) in the nozzle valve holder. Now place the nozzle valve in the drip tube.
3. Attach the suction tube (1) to the suction side. Only tighten the suction tube hand-tight!
4. Guide the clamping nut (2) onto the suction tube.
5. Attach the pressure hose (7) to the hose nozzle (6).
6. Now insert the suction tube into the container and tighten the clamping nut. Be sure that the CDS coupling and the suction tube is completely clean, to avoid pollution of the container content.
7. The suction tube will be inserted up to the floor of the container and secured with the clamping nut.
8. Secure the container against falling.

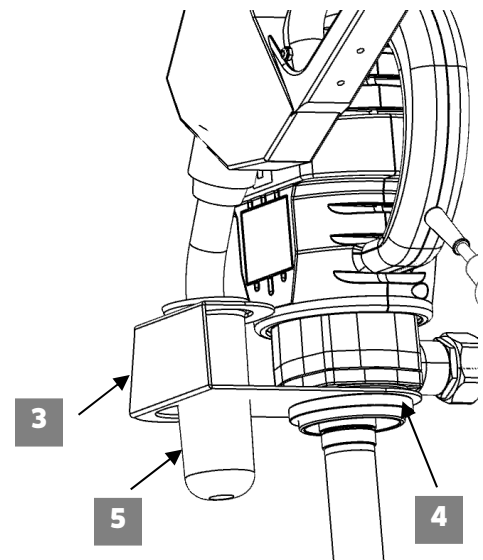
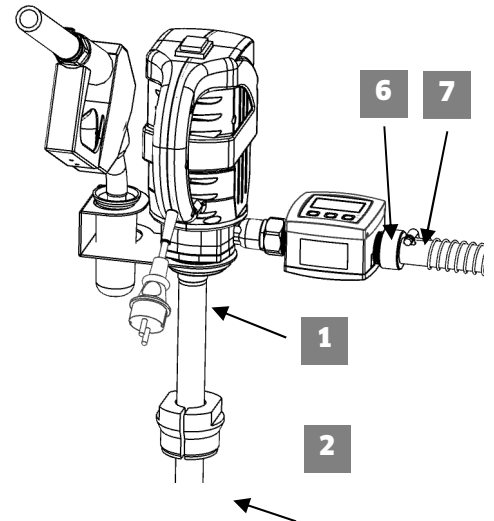

3.5 Installation Site

The pump is designed for installation within building and outdoors. The installation site should be selected so that flawless operation and maintenance are ensured. The pump can either installed directly on the tank or drum.



The regulations of the German Water Resources Act (WHG) and the German Ordinance for Systems with Substances Hazardous to Water (VAWS) must be complied with.

3.6 Note the Installation Location!



The suction tube will be on the bottom if the installation is correct.



In other installation locations the IP protection will be decreased and the cooling may be reduced. The operator must prevent the penetration of water by using, for example, an additional housing. The duty cycle and/or the maximum permissible environmental and media temperature will be decreased in the event of reduced cooling.

3.7 Temperature

The pump may be operated at environmental temperatures from -10 to +40°C and media temperatures from -7 to +40°C. Condensing humidity must be avoided. The pump system was flushed with demineralized water in the factory, so the pump system should not be stored at temperatures below 0°C.

3.8 Conveyance Capacity

The pump is designed for operation with tap hose DN19, tap valve A2003 and tap nozzle urea.

The installation of longer tap hoses or small cross sections reduces the conveyance capacity and may overload the pump. We recommend a max. 8m tap hose.

3.9 Electrical Connection

The pump is operated with alternating current 230v / 50Hz. The electricity consumption is 550W. The pump is equipped with a safety plug. The pump is outfitted with a power plug for the appropriate country.

4 Commissioning / Operation



The user must wear suitable protective clothing (eye protection, hand protection) as the risk of spraying exists during operation. You can find more information on the safety datasheet of the pump medium.



The system is rinsed with demineralized water at the factory and the storage temperature thus may not fall below 0°C. The system must be above 5°C for commissioning.



The HORNET W 85 H INOX electric pump may only be operated under supervision.

4.1 Suction / Dry Running

The HORNET W 85 H INOX pump works according to the self priming hybrid pump principle.

The suction process should be completed after a few seconds. If the pump has not taken in any medium after ca. 30 seconds, a problem exists (e.g. suction hose is leaking, tank is empty, suction height is too great).

If this occurs, the pump must be turned off immediately and the problem must be remedied.

The pump is equipped with a thermal dry run protection device that automatically switches the pump off. Once the thermal dry run detection has been triggered, the pump is to be switched off and left to cool down. The pump can be switched on again once it has cooled down.

If the motor is overloaded, a thermal cut-off switches it off. Similarly, when this happens, the pump is also to be switched off and left to cool down. If the pump is not switched off, it may start up again on its own.

Please ensure that pump is not run dry for an extended period of time. For the first use, the nozzle valve should be opened above a suitable container and then the start switch of the pump should be pressed. The conveyance system is free of air if no air bubbles escape the nozzle valve with the medium. This also applies for continued suction after refilling the container or changing the container.

4.2 Tank Procedure

Turn on the pump => pump will automatic suck in the medium.

Filling the vehicle tank and/or container.

Turn off the pump; place the tap nozzle aside.



Avoid long periods of operation with a closed tap nozzle!

Please note: The minimum tap quantity is 5 liters!

4.3 Meter FMT II (optional)

The HORNET W 85 H INOX is available in a variant with a turbine wheel flow meter FMT II. The FMT II has a five-digit digital display which automatically begins with the tap process. The display can be set back to 0 with the "Reset" button.

Please note the operation manual of the FMT II.

5 Automatic pump nozzle A2003-ES

5.1 Technical Description

5.1.1 General Description

The automatic pump nozzle A2003-ES is an automatically-closing full hose nozzle for the dispensing of fluids listed under no. 2.2. The A2003-ES automatic nozzle has been tested in accordance with the DIN EN 13012 standard.

The standard features of the nozzle include: a safety switching-off and a covering that protects against wear and cold conditions.

The type A2003-ES nozzle is made of stainless steel with an outlet diameter of 19 mm.

5.1.2 Appropriate use

The automatic nozzle is state of the art manufactured and is failsafe.



However hazards can arise from this product if it is not used according to specifications.

Each person concerned with the assembly, commissioning, maintenance and operation of the automatic nozzle must have read and understood the entire manual.



The automatic nozzle of type A2003-ES is only to be used for dispensing aqueous urea AUS32 as per ISO 22241!



Using the machine for any other purpose would constitute inappropriate use. The manufacturer shall not be liable for any resultant losses or damages; the risk shall be borne by the operating company alone in such cases.

Adherence to the assembly, commissioning, operating and maintenance conditions prescribed by the manufacturer also qualifies as proper use.

The automatic nozzle may only be used on dispensing installations with motor driven pumps. The volumetric flow of the delivery pump may not exceed 40 l/min or fall below **12 l/min**.

The zero delivery inlet pressure must not exceed 3.5 bar. The minimum operating pressure is 0.7 bar. The local safety and accident prevention regulations apply to the operation of the automatic nozzles.

Use extends to:

- Dispensing installations at petrol stations (in Germany: TRbF 40, No.4.1.1.6) and (TRWS 781-2)
- Filling of mobile containers and fuel tanks of working machinery outdoors (in Germany: TRbF 30, annex 4)
- Filling individual tanks with a capacity of up to 1000 litres for the storage of diesel fuel and heating oil (in Germany: TRbF 20, no. 9.3.2.3, section 3)

5.1.3 Function / Safety equipment

The closing valve of the A2003-ES automatic nozzle can only be opened manually using the control lever. An automatic shutdown occurs as a result of negative pressure or shaking when

- the tank is full, i.e. fuel fills the sensor jet on the outlet pipe.
- the nozzle is held vertically (see fig. B).
- the nozzle with control lever set falls to the ground.

Switching-off can also be performed manually by releasing the holding clip (if present) on the control lever.

5.1.4 Technical data

Length	approx. 450 mm
Minimum operating pressure	0,7 bar
Zero delivery pressure of the pump	max. 3,5 bar
Dispensing volume flow	min. 12 l/min max. 80 l/min (A2010) max. 40 l/min (A2003-ES, A2003-ES-M)

5.2 Requirements for the operating area



Among other the directives and regulations of the WHG §62 and §63 and VAWS §4 are to be followed regarding the support surface.

5.3 Operating instructions

The A2003-ES automatic nozzle is ready for use. No adjustment or lubrication needs to be carried out.

5.3.1 Installation instructions/ Commissioning

1. When installing the nozzle, do not attach tools to the nozzle or the protective bracket. Use the wrench only on the hose connection.
2. Attach the optional hose swivel joint supplied to the nozzle, making sure to fit the seal (flat seal or o-ring).
3. To avoid damage, do not overtighten the screwed connections. **Do not use Telefon sealing tape.**
4. After completing the installation, vent the pump nozzle and **check the connections under pressure for leaks. Check the shutdown function in all possible control lever positions.**

5.3.2 Operating instructions



Smoking is generally prohibited, also when drawing off diesel and heating oil and aqueous AUS32. Sources of ignition, such as fire, flying sparks etc., must be eliminated.



If the A2003-ES automatic nozzle is operated with a system other than the one supplied by us, a suitable pressure limiter must be installed because the automatic nozzle closes with pressure (max. operating pressure 3,5 bar)!

1. Insert the outlet pipe into the tank filler pipe to the extent that it will remain securely in the tank filler pipe (see fig. A). This also ensures that the nozzle shuts down when the fuel tank is full. Be sure that the nozzle is completely clean, before starting filling the tank.
2. For product variants with a holding clip guide the latter towards the protective bracket and latch the control lever.

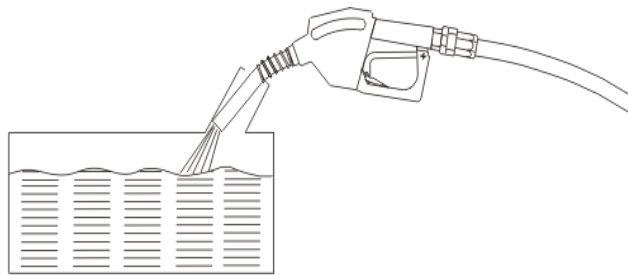

Fig. A

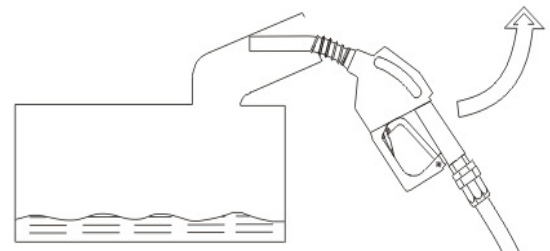

Fig. B

3. Once the nozzle has automatically shut down, tilt the nozzle towards the tank for a few seconds until the last drops have dripped out of the outlet pipe. This is also to be recommended when the filling procedure is ended manually.
4. If the nozzle can only be locked as shown in fig. B, it is not possible to fill the fuel tank. The nozzle shuts down immediately. Guide the nozzle in the direction of the arrow (see fig. B) to a position as shown in fig. A. The nozzle must be held in this position throughout the filling procedure. Items 2 and 3 apply accordingly.



If small amount are subsequently filled manually and when filling with the control lever locked, the volume flow may be less than the minimum allowed. In this case, the automatic shutdown of the nozzle can no longer work reliably! The fuel tank may be overfilled.



The filling process must be supervised even when using an automatically-closing nozzle!

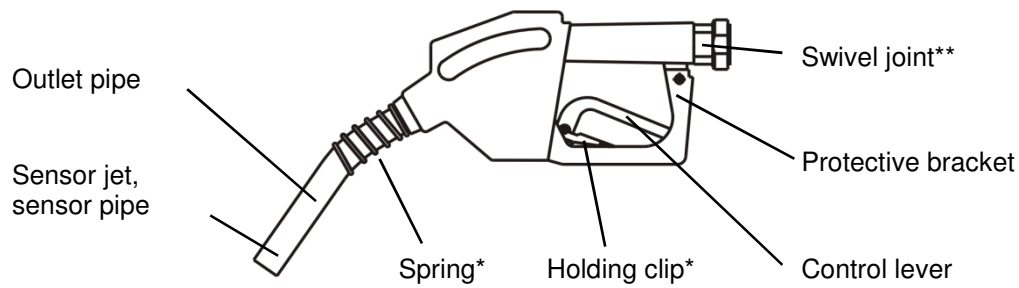

* only included in type A2010
** optional, see 2.3 Product variants

5.4 Maintenance

1. Make sure that the sensor jet on the outlet pipe is always open. The nozzle does not work if the sensor jet is dirty. Any dirt particles can be removed using a suitable wire.
2. Always hang up the nozzle securely after use so that it cannot fall. Handle the automatic pump nozzle with care.
3. Greasing or oiling is not necessary.
4. The automatic nozzles A2003-ES for AUS32 use should be cleaned regularly with warmed distilled water.

6 Flow Meter FMT II

6.1 Technical Description FMT II

6.1.1 Display

LC display with five-digital quantity display with 16 mm high numbers as well as display of the mass unit liter (optional US gallon, UK gallon) and indication of low batter capacity.

The smallest numeric increment of the measured value is 0.01 liters; the smallest numeric increment of the un-resettable totalizer is 1 liter.

6.1.2 Keyboard

Membrane keyboard with three buttons: "Total", "Reset" and "Mode".

6.1.3 Battery

Lithium battery (type CR ½ AA, 3.6V, 1200 mAh) with a minimum lifetime of ca. 10 years with a flow quantity of 1,000,000 liters over this period.

The battery can be replaced by opening the housing. Sum and calibration values will be retained after battery replacement.

6.1.4 Measured Value Recording

Recording of the pulse signals of the measurement chamber.

Error redundant storing and readout of the mass unit and calibration factor.

6.2 Operation FMT II

6.2.1 Delivery Condition

The meter is preset at the factory with the mass unit "liter" and the calibration factor "1,000". Pre-inspected meters have already had the calibration factor adjusted at the factory; this can also be conducted later. The meter is ready to measure discharge without any further configuration.

6.2.2 Basic Condition, Flow Measurement

In the basic condition, the volume measured since the last reset will be displayed on the LC display. The display takes place with three pre-decimal positions and two post-decimal positions; the smallest numerical increment is 0.01 liters. The mass unit "liter" (optional US gallon, UK gallon) is displayed in the lower line.

The buttons are locked during measurement.

6.2.3 Reset - "Reset" Button

After pressing the "reset" button, the program status will be displayed for as long as the button remains pressed. When the button is released, a test of all segments and the resetting of the volume meter will take place. If pulse signals are received (volume flow), the display test will be stopped and the device will switch to the basic condition.

6.2.4 Totalizator - "Total" Button

After pressing the "total" button, the totalizator condition will be displayed for as long as the button remains pressed. The display takes place rounded into liter (optional US gallon, UK gallon). If pulse signals are received (volume flow), the display of the totalizator condition will be stopped and the device will switch to the basic condition.

6.2.5 Display of the Calibration Factor - "Total" + "Reset" Buttons

If the "reset" button is also pressed while the "total" button (display of the totalizator condition) is being held, the programmed calibration factor will be displayed for as long as both buttons remain pressed. The calibration factor may be within the range of 0.500 to 1.500.

7 Error Message - What to do, if...?

... the pump turns itself off and cannot be switched on again?

The pump has overheated because it ran dry and can only be used again once the pump chamber has cooled down sufficiently. Turn off the pump, eliminate the cause of the pump running dry, and let the pump cool down. Possible causes: Reservoir empty or incorrectly mounted CDS coupling.

...the pump keeps turning on and off?

The motor turns off when it is overloaded, and starts up again by itself once it has cooled down sufficiently. Turn off the pump and eliminate the cause of the overload. Possible causes: Blocked rotor; medium too viscous.

... The bottom of the pump is leaking?

The O ring of the pump chamber or the suction ports are leaking and must be replaced.

... The pump is leaking at the pressure ports?

Check that the screws on the pressure side are tight and reseal them if necessary.

... The pump is not sucking (e.g. first use, longer period of non-use)?

Check the suction hose and all screws on the suction side for leaks and reseal them if needed.

... The conveyance capacity is too low?

Air is also being sucked in.

... the flow meter is clearly showing more than the dispensed quantity?

The suction hose has a leakage and the sucked air is also counted. Reseal the suction hose and clean the CDS-coupling.



In the event of disproportionate noise, further operation is only allowed after the cause of this has been remedied!

8 Maintenance

The HORNET W 85 H INOX is nearly maintenance-free, however, the following work should be conducted regularly in order to ensure flawless operation.

8.1 Leak Test

The device and the other components of the system are to be checked regularly for leaks and damages and are to be repaired if needed.

The sealing side from CDS-coupling shall be regularly cleaned!

8.2 Cleaning the System

In the event of external dirt on the device, disconnect it from the electrical network and carefully clean it with a mild household cleaning product. Do not use any aggressive cleaning products or solvents.

9 Replacement Parts

9.1 Replacement Parts Standard bracket

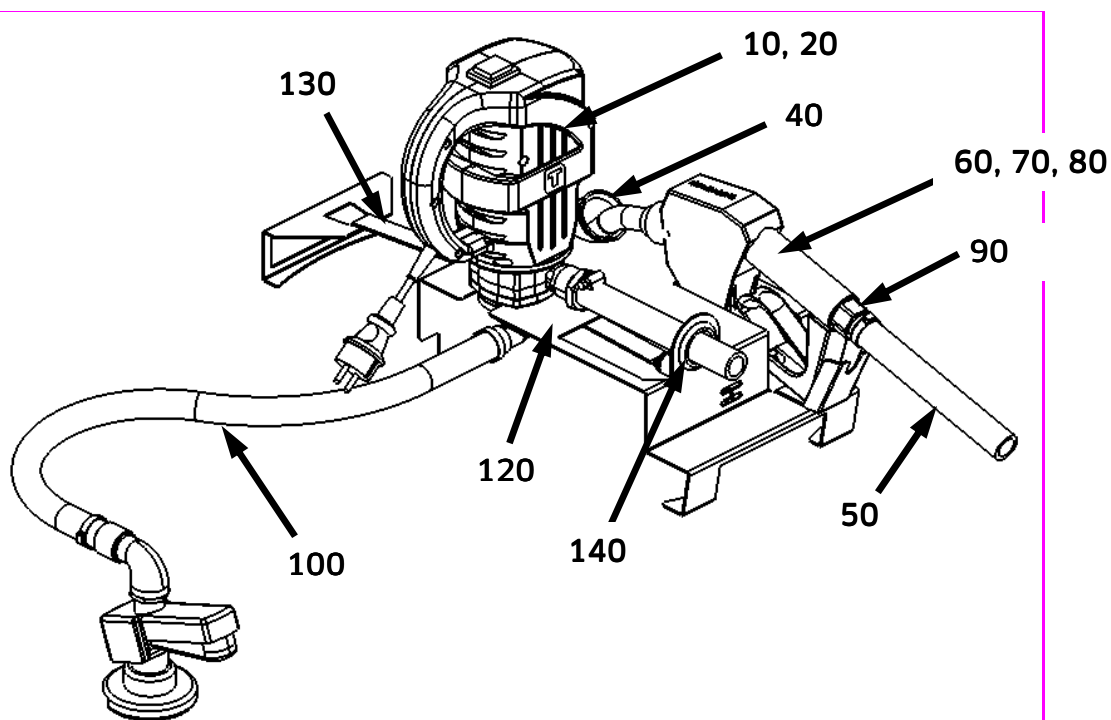

Pos.	Quantity	Production No.	Designation
10	1	816 428 007	Pump kit incl. FMT meter
20	1	816 428 008	Pump kit without meter
30	1	514 980 093	Belt with spring and hooks
40	1	515 610 012	Drip tube
50	1	814 988 019	Tap hose including Hose clamp Anti-kink spring Hose shell
60	1	252 711 020	Tap valve urea without catch / without rotatable fittings
70	1	252 711 021	Tap valve urea with catch / without rotatable fittings
80	1	252 350 000	Plastic valve urea with rotatable fittings
90	1	814 980 016	Rotable fittings stainless steel
100	1	814 980 015	Suction hose including CDS coupling
110	1	816 428 003	Pump rotor including O ring for pump chamber INOX
120	1	816 420 023	Bracket incl. strap, spring, hooks and collection pipe

130	1	492 000 800	Tightening strap
140	1	453 100 950	Hose protection (only for variants without FMT II)

9.2 Replacement parts for side bracket

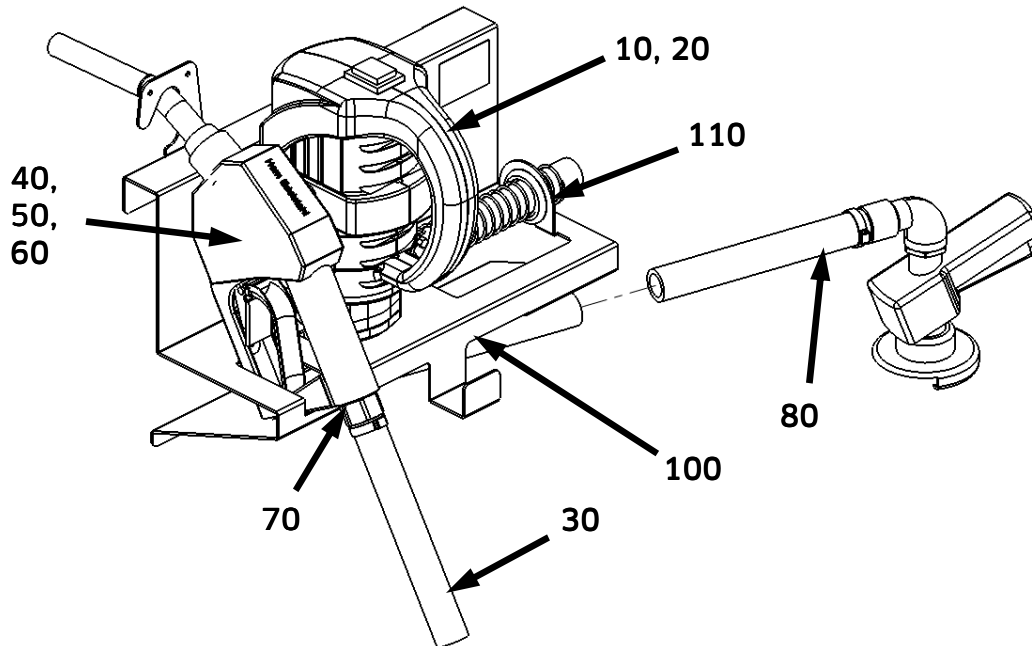

Pos.	Quantity	Production No.	Designation
10	1	816 420 026	Pump kit incl. FMT meter
20	1	816 420 027	Pump kit without meter
30	1	814 988 021	Tap hose including Hose clamp Anti-kink spring Hose shell
40	1	252 711 020	Tap valve urea without catch / without rotatable fittings
50	1	252 711 021	Tap valve urea with catch / without rotatable fittings
60	1	252 350 000	Plastic valve urea with rotatable fittings
70	1	814 980 016	Rotable fittings stainless steel
80	1	816 420 025	Suction hose including CDS coupling
90	1	816 428 003	Pump rotor including O ring for pump chamber INOX
100	1	516420049	Bracket
110	1	453100950	Hose protection (only for variants without FMT II)

9.3 Replacement Parts Drum Transfer Pump

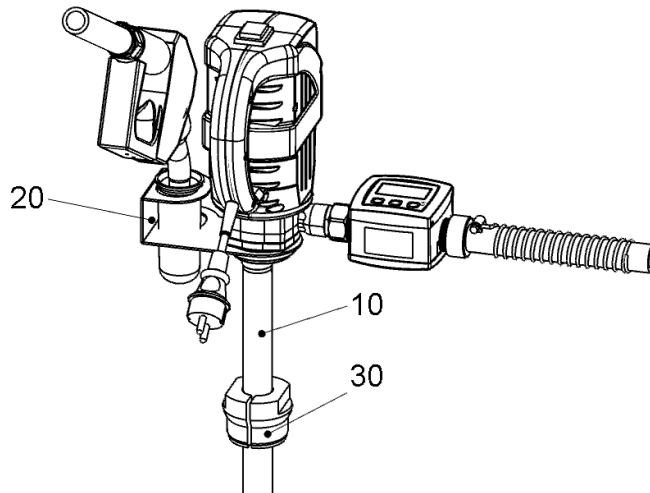

Not listed production numbers are the same as with the IBC Console Pumps.

Pos.	Quantity	Product No.	Designation
10	1	816 158 001	Suction tube with clamping nut and O ring
20	1	816 428 006	Tap valve holder including Drip tube IG2" nut
30	1	209 051 000	Clamping nut
		816 428 009	Pump kit incl. FMT meter
		816 428 010	Pump kit without meter

9.4 Instructions for Replacing the Pump Rotor

1. Loosen the four screws (1) at the bottom of the pump chamber.
2. Remove the suction housing (2) and replace the rotor (3).
3. Always replace the O ring (4) when replacing the rotor.
4. After properly positioning the rotor and replacing the O ring, place the suction housing back on the pump chamber (5).
5. Now tighten the four screws with a torque of 3.0 Nm.
6. The suction housing can now be fixed in a position with the four screws on the pump chamber.

Pos.	Quantity	Product No.	Designation
30	1	404 108 150	O ring
40	1	515 560 029	Rotor

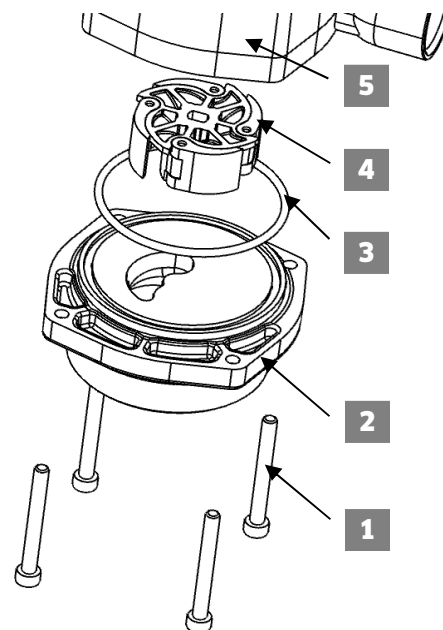

The pump and the flow meter may only be repaired and replaced by authorized service partners.

10 Disposal

The device is to be completely emptied during decommissioning and the fluids are to be properly disposed of. In the event of the final decommissioning of the HORNET W 85 H INOX, the device is also to be disposed of properly:



- Dispose of the scrap metal parts in the scrap metal recycling.
- Dispose of the plastic parts in the recycling.
- Dispose of the electrical scrap in the recycling.



The water regulations must be heeded.

10.1 Return of batteries

Batteries must not be disposed of with the domestic waste. Batteries can be returned free of charge via a suitable collecting point or to the dispatch stores. Consumers are legally obliged to return used batteries.

Batteries that contain harmful substances are marked with a crossed out dustbin (see above) and the chemical symbol (Cd, Hg or Pb) of the heavy metal that is decisive for the classification as containing harmful substances:

1. "Cd" stands for cadmium.
2. "Pb" stands for lead.
3. "Hg" stands for mercury.

11 Scale Image of the HORNET W 85 H INOX

Ein/Aus Schalter
on/off switch

Alle medienberührten Teile sind aus folgenden Materialien: Edelstahl, PEEK, NBR
all media contacted parts are made of these material: stainless steel, PEEK, NBR

HORN TECHNICAL	
HORN GMBH & CO. KG D-24937 ELSNABURG	
Name	A. Schröder
Bestell-Nr.	03.08.10
Gepl.-Nr.	03.08.10
Preis-Nr.	04.08.10
ART. Nr.:	
<input type="radio"/> AV	<input type="radio"/> WE
<input type="radio"/> M.1	<input type="radio"/> M.2
<input type="radio"/> M.3	<input type="radio"/> M.4
<input type="radio"/> Drehtriebe	<input type="radio"/> E-MONT
Zeichnung nach DIN ISO 2768 - Toleranzklasse m-K Oberflächen nach DIN ISO 1302 CAD-Daten: www.horn-technic.com Druckdatum: 01.11.2010	



Konformitätserklärung Declaration of Conformity

Hiermit erklären wir, dass die Bauart
We herewith declare that the construction type

Typ: **Hornet W 85 H INOX**
Type: **Hornet W 85 H INOX**

Bezeichnung: **Elektrische Förderpumpe**
Designation: **Electric pump**

Artikel-Nr.: 108600000, 108600100, 108600110, 108600200, 108600210,
Item No.: 108600300, 108600310, 108600400, 108600500, 108600600,
108601100, 108601110, 108601200, 108601210, 108601400,
108601500, 108611200, UK108600000, UK108600210,
UK108600300, UK108600310, UK108600500, UK108600600,
UK108601100, UK108601210, UK108601500

in der von uns gelieferten Ausführung folgenden einschlägigen Bestimmungen entspricht:
in the form as delivered by us complies with the following applicable regulations:

- Maschinenrichtlinie 2006/42/EG
Machinery safety 2006/42/EC
- EMV-Richtlinie 2004/108/EG
Electromagnetic compatibility 2004/108/EC

Angewendete harmonisierte Normen: EN ISO 12100-1, -2
Applied harmonised standards: EN 60204-1

EG-Dokumentationsbevollmächtigter: Jörg Mohr Horn GmbH & Co. KG
EC official agent for documentation: Munketoft 42
24937 Flensburg

07.01.2014
Datum
Date

.....
i.V. Dipl.-Ing. Jörg Mohr
Entwicklungsleiter / *Engineering Manager*

HORN GmbH & Co. KG
Munketoft 42
D-24937 Flensburg
Germany

T +49 461 8696-0
F +49 461 8696-66
info@tecalemite.de
www.tecalemite.de

Geschäftsführer:
Torsten H. Kutschinski

Commerzbank AG
BLZ 215 400 60
Konto-Nr. 2476000

SWIFT COBADEFFXXX
IBAN DE33215400600247600000
Amtsgericht Flensburg HRA 4264
USt-IdNr. DE813038919

HORN GmbH & Co. KG

Munketoft 42
24937 Flensburg
Germany

T +49 461-8696-0
F +49 461-8696-66

www.tecalemit.de
info@tecalemit.de