

Safe Storage
Great Britain

Protected By



Agricultural Range

Explore the full range of Kingspan Agricultural Solutions



kingspan.com



Cattle Drinkers

The Kingspan range of tough cattle drinkers represents the best products of their kind available in the market. Simple and economical, these cattle drinkers come in a wide variety of sizes.

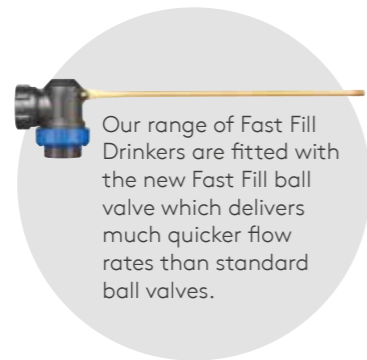

Our range of Fast Fill Drinkers are fitted with the new Fast Fill ball valve which delivers much quicker flow rates than standard ball valves.

Features

- Rotationally moulded from top quality medium density polyethylene.
- Ultraviolet stabilised for protection against sunlight.
- Extremely durable.
- Excellent impact strength, lightweight and easily transported.

Cattle Drinkers



12G DRINKER AD01

Capacity*	58 Ltrs
Length	680 mm
Width	440 mm
Height	353 mm



30G DRINKER AD02

Capacity*	126 Ltrs
Length	1225 mm
Width	535 mm
Height	465 mm



40G DRINKER AD27

Capacity*	182 Ltrs
Length	1280 mm
Width	475 mm
Height	570 mm



90G DRINKER AD03

Capacity*	353 Ltrs
Length	1400 mm
Width	610 mm
Height	620 mm



MEAL BIN AD83

Capacity*	1000 Ltrs
Length	220 Gals
Length	1375 mm
Width	1200 mm
Height	920 mm



Fast Fill Drinkers



30GAL DRINKER AD122

Capacity*	136 Ltrs
	30 Gals
Length	1210 mm
Width	555 mm
Height	460 mm
Sludge Outlet	1" drain outlet

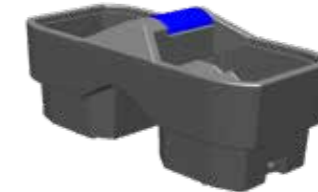

90GAL DRINKER AD123

Capacity*	409 Ltrs
	90 Gals
Length	1555 mm
Width	735 mm
Height	650 mm
Sludge Outlet	1" drain outlet



120GAL DRINKER AD92

Capacity*	545 Ltrs
	120 Gals
Length	2200 mm
Width	800 mm
Height	560 mm
Sludge Outlet	1 1/2" (x 2)



170GAL DRINKER AD93

Capacity*	770 Ltrs
	170 Gals
Diameter	1575 mm
Height	660 mm
Sludge Outlet	1 1/2"



250GAL DRINKER AD94

Capacity*	1136 Ltrs
	250 Gals
Diameter	1720 mm
Height	860 mm
Sludge Outlet	1 1/2"



400GAL DRINKER AD95

Capacity*	1800 Ltrs
	400 Gals
Diameter	2060 mm
Height	810 mm
Sludge Outlet	1 1/2"

Livestock Drinkers

Strong Rotomoulded PE Water drinkers to suit all Livestock requirements. All drinkers come complete with float and valve.



DRINKER

Capacity*	23 Ltrs
Length	370 mm
Width	420 mm
Depth	380 mm

*capacities may vary



Animal Feeders



Available in various sizes.



Milk Feeders

Heavy duty polyethylene milk feeders designed to suit calves. All feeders are designed to secure over gate or rail.

- Designed as a milk delivery system for 1 to 5 calves (fitted with peach teats)
- Available in black & white (1MF)
- Available in grey, orange & white (3MF/5MF)
- Separate compartments reduce risk of cross-contamination
- Easily cleaned/increased hygiene
- Each compartment holds approx. 2.5 litres (3MF/5MF)

		
1MF	3MF	5MF
Length 290 mm Width 230 mm Height 310 mm	Length 530 mm Width 260 mm Height 260 mm	Length 950 mm Width 260 mm Height 260 mm

Floor Trough

- Heavy duty polyethylene material ensures a robust hygienic product but allows for easy manoeuvrability
- Available in 4ft and 6ft



4FT
Length 1480 mm Width 710 mm Height 300 mm
6FT
Length 1828 mm Width 710 mm Height 300 mm

Footbaths

- Moulded splash guard to retain liquid
- Narrow base to economise on amount of foot dip needed
- Ridges on the bottom to avoid slipping
- Anti-slip rubber matting to provide livestock comfort (5ft only)
- Manufactured from heavy duty polyethylene for strength and durability

		
SHEEP FOOTBATH (5FT)	SHEEP FOOTBATH (8FT)	CATTLE FOOTBATH (8FT)
Length 1500 mm Width 535 mm Height 180 mm	Length 2400 mm Width 460 mm Height 210 mm	Length 2400 mm Width 700 mm Height 240 mm

Boot Bath, Chemical Store, Maxi Bunker & Maxi Store

Boot Bath

Boot bath ideally used at the entrance of poultry units, piggeries and dairies etc. to disinfect, clean and decontaminate boots before entering and help the control of disease.

Manufactured in bright yellow helps the boot bath stand out so that it can be seen easily and be more readily used by visitors to the

site. It also has a lid that is easily flipped open with your foot. The lid is designed to keep rainwater out and helps avoid the solution becoming diluted.

Length	510 mm
Width	485 mm
Height	250 mm



Chemical Store

The large bunded store is ideal for the storage of dry chemicals (powders) and features fully lockable lid, removable powder store and a galvanised floor.

- Lid is lockable ensuring contents are securely stored (lock not included)

- Polyethylene divider included for separating contents

CHEMICAL STORE AD96

Length	1140 mm
Width	540 mm
Height	670 mm



Maxi Bunker



FCBU	
Capacity	30x25 kg Bags
Length	1920 mm
Width	1060 mm
Height	1000 mm

These bunkers were primarily designed to provide an attractive and secure display for a forecourt, but have evolved into a multi-functional storage container.

- Moulded in impact and UV resistant MDPE to give an exceptionally strong, long life construction.
- Rust, rot and weather resistant.
- Fully retractable roof for exposing products.
- Black, red, green or blue colours available on request.
- Requires no assembly and is easy to access for filling and emptying.
- Each MAXI bunker is supplied with a padlock.
- Suitable for forecourt location - storing pre-packed products such as wood, coal, charcoal or pet food.
- May be fitted with hasp and staple (on request).

Maxi Store



MAXISTORE BK	
Length	1140 mm
Width	540 mm
Height	670 mm

A compact container, suitable for a variety of storage needs, anything from domestic and agricultural to commercial whether indoor or outdoor.

- Lid is lockable ensuring contents are securely stored (lock not included).
- Moulded in impact and UV resistant MDPE to give an exceptionally strong, long life construction.
- Rot, rust and weather resistant.
- Available in black as standard. Other colours are available on request.
- Black polyethylene divider included for separating contents.
- Suitable for secure holding of paint etc, pet food, toys, bags of wood or small garden equipment.

Grit Bins & Coal Bunkers

Grit Bins

Designed with the suitability and endurance required for public locations, these containers are primarily for the storage of salt and sand, for using in icy weather to keep paths and driveways slip free, but are also suitable for grain and garden equipment.



Features

- > May be fitted with hasp and staple (on request)
- > Vandal resistant double skin lid which makes it ideal for public locations
- > Highly visible yellow

GB200

Capacity	200 kg
Length	790 mm
Width	480 mm
Height	790 mm

GB400

Capacity	400 kg
Length	1020 mm
Width	610 mm
Height	1020 mm

Coal Bunkers



B150KG

Capacity	150 kg
Length	850 mm
Width	600 mm
Height	770 mm



B300KG

Capacity	300 kg
Length	950 mm
Width	880 mm
Height	970 mm



B600KG

Capacity	600 kg
Length	1190 mm
Width	970 mm
Height	1140 mm

Logstore

AD62BK

Length	1280 mm
Width	780 mm
Height	950 mm



Potable Water Tanks

Capacities from 900-10,000 Litres



Specifically designed to store water for animal drinking or emergency human consumption, Kingspan potable water tanks are made from WRAS approved material.



R900WP

Capacity	900 Ltrs/198 Gals
Outlet	1" BSP Male
Length	1505 mm
Width	695 mm
Height	1200 mm



R1200WP

Capacity	1200 Ltrs/ 264 Gals
Outlet	1" BSP Male
Length	1820 mm
Width	720 mm
Height	1220 mm

V1300WP

Capacity	1300 Ltrs/285 Gals
Outlet	2" BSP male
Dia.	1210 mm
Height	1415 mm

All tanks are also available in non potable versions, supplied in grey. Please quote corresponding codes, R900W, R1200W, V1300W, V2500W, V3600W, V5000W, V10000W



V2500WP

Capacity	2500 Ltrs/550 Gals
Outlet	2" BSP male
Dia.	1635 mm
Height	1450 mm



V3600WP

Capacity	3600 Ltrs/800 Gals
Outlet	2" BSP male
Dia.	1885 mm
Height	1855 mm



V5000WP

Capacity	5000 ITRS/1100 Gals
Outlet	2" BSP male
Dia.	2035 mm
Height	2265 mm



V10000WP

Capacity	10000 Ltrs/2200 Gals
Outlet	2" BSP male
Dia.	2630 mm
Height	2500 mm

*10 year warranty applies to the tank only

Large Scale Storage Solutions

15,000-litre Liquid Fertiliser, AdBlue® & Water Storage Solutions



AgriMaster Liquid Fertiliser

AM15000

Weight: 340 kg

- Can hold up to 1.4 SG liquid fertiliser solution
- Easily monitor liquid fertiliser levels with the tank's semi-transparent design

BlueMaster AdBlue®



BM15000

Weight: 310 kg

- Can hold up to 1.1 SG AdBlue® solution
- AdBlue® level is readily visible to the eye due to the tank's semi-transparent colour

AquaBank Water



AB15000

Weight: 365 kg

The Benefits of Black Colour:

- Algae growth prevention
- Preserves rainwater quality
- Enhanced water heating efficiency

Features & Benefits

- **Superior Construction**
Crafted as a single, seamless unit for ultimate durability.
- **Quality Material**
Engineered from high-quality polyethylene for outstanding strength.
- **Smart Monitoring**
Local or remote level monitoring options are available.
- **Corrosion-Free**
Resists rust and degradation for long-lasting reliability.
- **Maintenance-Free**
No repainting needed, ensuring hassle-free ownership.
- **Weatherproof**
UV stabilised to withstand harsh weather conditions.
- **Easy Transport**
Fits standard trucks for effortless mobility.
- **Simple Installation**
Compatible with farm equipment for easy setup and relocation.

Dimensions

Height 3660 mm
Diameter 2480 mm

Specification

- Access lid 22"
- Inspection lid 8"
- 2" (or optional 3") bottom outlet fitted with stainless steel ball valve
- Ventilation outlet
- 4 Lifting Points
- Moulded in mounting points
- Stainless steel fittings with EPDM rubber gaskets

Rainwater Harvesting & Storage Systems

RainStore Above Ground Retrofit Rainwater Storage Systems

The free standing tanks require no specialist installation and come in sizes that will really make a difference to metered properties and areas prone to water restrictions in summer months. The RainStore Range of rotationally moulded storage tanks are tough, durable and built to last.



RSS0450		RSS0900	
Capacity	5000 Ltrs	Capacity	10000 Ltrs
Diameter	2000 mm	Diameter	2630 mm
Height	2500 mm	Height	2700 mm
Outlet	2" BSP Male	Outlet	2" BSP Male

RainStore Standard Package includes:

- Tank(s)
- Integrated Leaf Filter
- Calmed Inlet
- Siphon Overflow
- Rainwater Inlet from Roof
- 2" BSP Outlet
- Mains Top Up Valve

Klargester Wastewater Solutions

A solution for every wastewater and surface water application

Silent operation 	Odour Free 	Trusted and reliable performance 	Warranty*
----------------------	----------------	--------------------------------------	---------------

Benefitting from 70 years experience, Klargester offer a range of reliable wastewater and surface water solutions. Our tried and tested product range includes sewage treatment plants, septic tanks, pumping stations, fuel and oil separators and rainwater harvesting solutions.



Klargester BioDisc®

Typical Applications:



- > Single & Multiple Homes
- > Barn Conversions
- > Farms
- > Light Industrial Premises

Free technical site visit available by your local Klargester Area Manager. To arrange a call: **01296 633 033**

* T&C's Apply

FuelMaster®

Diesel Storage & Dispensing Solutions
Available from 1,200-5,000 Litres

HVO Ready 	CE marked** 	Tank Guarantee*** 
---	--	--



FM1200
Capacity* 1200 Ltrs/ 264 Gals
Length 1150 mm
Width 1200 mm
Height 1430 mm



FM1225
Capacity* 1225 Ltrs/269 Gals
Length 2050 mm
Width 900 mm
Height 1970 mm



FM1300
Capacity* 1300 Ltrs/286 Gals
Length 1920 mm
Width 1230 mm
Height 1785 mm



FM2500
Capacity* 2500 Ltrs/550 Gals
Length 2460 mm
Width 1460 mm
Height 1950 mm





FM3500
Capacity* 3500 Ltrs/755 Gals
Length 2850 mm
Width 2200 mm
Height 1960 mm



FM5000
Capacity* 5000 Ltrs/1100 Gals
Length 2850 mm
Width 2250 mm
Height 2350 mm

*Capacities may vary
**CE mark applies to the primary storage tank
***10 year warranty applies to the tank only

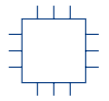
TITAN FuelMaster®

Faster Pumps 	Digital Flowmeter 	Motion Sensor light 
---	--	--

Tank Dimensions & Specifications

Capacity (Litres/Gallons)	Length (mm)	Width (mm)	Height (mm)
1,200 / 264	1,150	1,200	1,430
1,225 / 269	2,050	900	1,970
1,300 / 286	1,920	1,230	1,785
2,500 / 550	2,460	1,460	1,860
3,500 / 770	2,850	2,200	1,960
5,000 / 1,100	2,850	2,250	2,350

Specification	Standard 1200-5000L	Advanced 1225-5000L	Smart 1225-5000L	PRO 3500-5000L
Digital Flowmeter (Smart Spec - pulser flowmeter linked to Watchman Flo)				
Motion Sensor Light				
Junction Box for Wiring				
Mechanical Level Clock Gauge				
Watchman Flo Tank Monitor				
Watchman Access Fuel Management System				

Tank Features that come as standard:

- Lockable Lid
- 72 lpm* Pump 230V
- 1" Suction Line
- Auto Shut-Off Nozzle
- 10 Micron Particle & Water Filter
- 2" BSP Coupling for filling
- Spillstop Mechanical Overfill Protection
- Nozzle Holder
- 6m Hose**
- Drip tray in Cabinet***

Power and Safeguard your Business

- Industry Leading Approvals - CE marked according to EN13341
- Quality Assured - Made in EN ISO 9001 facility

*Maximum across pump flow rate as defined by pump manufacturer. Actual flowrate will be less.
**All capacities come with 6m hose except for 1200L tanks, they come with 4m hose
*** Drip tray in cabinet is only available for 3500-5000L capacities

TruckMaster®

Portable Diesel Storage & Dispensing Solutions
Available from 200-900 Litres

HVO Ready 	ADR Approved* 	Tank Guarantee** 
---	--	---



 TM200 Capacity 200 Ltrs/44 Gals Length 600 mm Width 800 mm Height 620 mm Weight 33kg	 TM300 Capacity 300 Ltrs/66 Gals Length 600 mm Width 800 mm Height 890 mm Weight 45kg
 TM430 Capacity 430 Ltrs/95 Gals Length 1180 mm Width 860 mm Height 910 mm Weight 64kg	 TM900 Capacity 900 Ltrs/198 Gals Length 1410 mm Width 1050mm Height 1210 mm Weight 97kg

TM430/300 Equipment Specification

1. Tank
2. 12V Pump
3. Automatic nozzle (with optional flowmeter, if required)
4. Pressure relief vent
5. Delivery hose
6. Lockable lid***
7. Shackles†
8. 4" Inspection lid††
9. Filling offset†††
10. Internal LED Light†††
11. Gas Strut

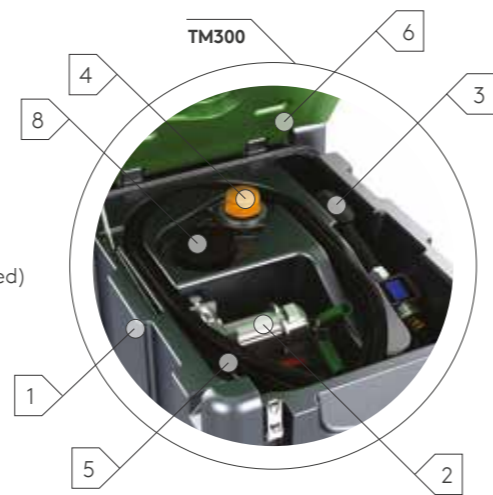

Model Selector

All dimensions and weights are an approximate only

* 200 and 300 litre models do not require ADR approval due to their smaller capacity

** 5 year warranty applies to the tank only

*** Lid with integrated lock (TM430 and TM900). Lid with lockable latch, padlock not provided (TM200 and TM300)

† Available on TM430 and TM900 as optional extra

†† Available on TM200, TM300

††† Available on TM430 and TM900 as optional extra

BlueMaster®

AdBlue Storage & Dispensing Solutions
Available from 2500-9000 Litres

Tank Guarantee* 
--



BM2500
Capacity 2500 Ltrs / 550 Gals
Length 2460 mm
Width 1460 mm
Height 1860 mm



BM5000
Capacity 5000 Ltrs / 1100 Gals
Length 3900 mm
Width 1150 mm
Height 2340 mm



BM5000
Capacity 5000 Ltrs / 1100 Gals
Length 2850 mm
Width 2250 mm
Height 2350 mm



BM9000
Capacity 9000 Ltrs / 1980 Gals
Length 3280 mm
Width 2450 mm
Height 2950 mm

Features:

- > Double skinned tank
- > 2" SS dry coupling filling connection
- > Submersible pump
- > Automatic Dispensing Nozzle
- > Manual Pump Switch
- > 3/4" EPDM Delivery Hose (6m on 2500L and 8m on 5000L Vertical & Slimline and 9000L)
- > Light in housing

BlueMaster® STANDARD With Tank Monitoring System

KINGSPAN SENSOR TANK MONITORING SYSTEM (TMS)

The Tank Monitoring System when fitted to the BlueMaster Standard tank offers the following key features:

- > Power supply for system devices
- > LCD display
- > Pump on/off control via nozzle holder switch
- > Control of heating and ventilation
- > Leak detection alarm
- > Overfill alarm
- > Flow measurement via external flowmeter
- > Contents measurement via pressure sensor
- > Nozzle position indication
- > Housing light control
- > 4-20 mA output
- > 100 impulse/litre output



*10 year warranty applies to tank only



TITAN EcoSafe® Oil Storage Tanks

Complete bunded oil storage tanks available from 1000 - 5000 Litres



ES1000

Capacity 1000 Ltrs/
220 Gals
Length 2150 mm
Width 690 mm
Height 1500 mm
Footprint 2150 x 690 mm



ESSL1100

Capacity 1100 Ltrs/
242 Gals
Length 1920 mm
Width 600 mm
Height 1580 mm
Footprint 1800 x 600mm



ESSL1400

Capacity 1400 Ltrs/
308 Gals
Length 2200 mm
Width 650 mm
Height 1680 mm
Footprint 2105 x 650 mm



ESLP1200GB

Capacity 1200 litres/
264gal
Length 1800 mm
Width 1200 mm
Height 960 mm
Weight 130 kg



ES1225

Capacity 1225 Ltrs/
269 Gals
Length 2050 mm
Width 900 mm
Height 1525 mm
Footprint 2050 x 900 mm



ES1300

Capacity 1300 Ltrs/
286 Gals
Length 1920 mm
Width 12300 mm
Footprint 1915 x 1230 mm



ESV1300

Capacity 1300 Ltrs/
286 Gals
Diameter 1550 mm
Height 1490 mm



ES1800

Capacity 1800 Ltrs/
396 Gals
Length 2370 mm
Width 1285 mm
Height 1355 mm
Footprint 2370 x 1285 mm



ESSL2000

Capacity 2000 Ltrs/
440 Gals
Length 2500 mm
Width 800 mm
Height 1700 mm
Footprint 2350 x 800 mm



ES2500

Capacity 2500 Ltrs/
550 Gals
Length 2450 mm
Width 1425 mm
Height 1490 mm
Footprint 2445 x 1425 m



ESV2500

Capacity 2500 Ltrs/
550 Gals
Diameter 2000 mm
Height 1490 mm



ES3500

Capacity 3500 Ltrs/
770 Gals
Diameter 2180 mm
Height 1945 mm

*The CE mark applies to the primary storage tank.
**10 year warranty applies to tank only.

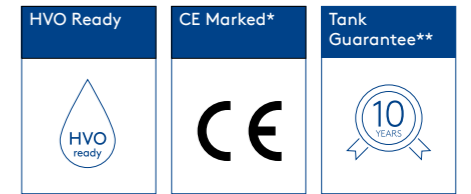

Features

- › SpillStop overfill prevention device fitted as standard. This device shuts off once fuel reaches approx.95% of the tank capacity.
- › The double skin construction ensures environmental protection and safeguards against leaks and ground contamination
- › Increased security due to lockable lid protecting your fuel
- › Remote oil level monitor reduces the possibility of running out of oil (sudden drop alarm and low level alert)
- › Bottom outlet, unique gate valve and filter supplied as standard

Watchman Tank Pack NEW

All EcoSafe tanks come complete with Watchman tank pack, which includes a Watchman Sonic Advanced Tank monitor, PTFE tape and the Kingspan 2-Part Valve.

The new Kingspan 2-Part Valve features a safe isolation shut-off valve and a 10-micron particle filter. It offers instant isolation, debris removal, and pollution-free operation, saving hours of labour by eliminating the need to drain the tank for filter replacement.

SENSIT Ready

It is possible to upgrade to Watchman



Fuel Type: Kerosene (C1/C2), Fuel Oil (A2), Gas Oil/Diesel (D) and biofuel as defined in BSEN2869, BSEN590 and BSEN14214.

Contact Details

UK

Kingspan Water & Energy Ltd.

180 Gilford Road

Portadown,

BT63 5LF

T: +44 (0) 28 3836 4444

E: tankinfo@kingspan.co.uk



We take every care to ensure that the information in this document is accurate at the point of publication. Specification may vary (within a small parameter) due to manufacturing process variations or environmental conditions. All images are for illustration purposes only and should not be taken as binding. The actual product may vary, and specification/dimensions/colour/other attributes may differ. To ensure you are viewing the most recent and accurate product information, please scan the QR code above. ©Kingspan and the Lion Device are Registered Trademarks of the Kingspan Group in the UK, Ireland and other countries. All rights reserved. Registered in Country No.NI017631. Registered Office: 180 Gilford Road, Portadown, Co. Armagh, BT635LF. VAT GB412 5124 03

04/2025_v3_4559_C24.10041

