

Klargester Wastewater Solutions

# **Klargester** AquaPump Stations Product Guide

Complete Wastewater and  
Surface Water Pumping Solutions

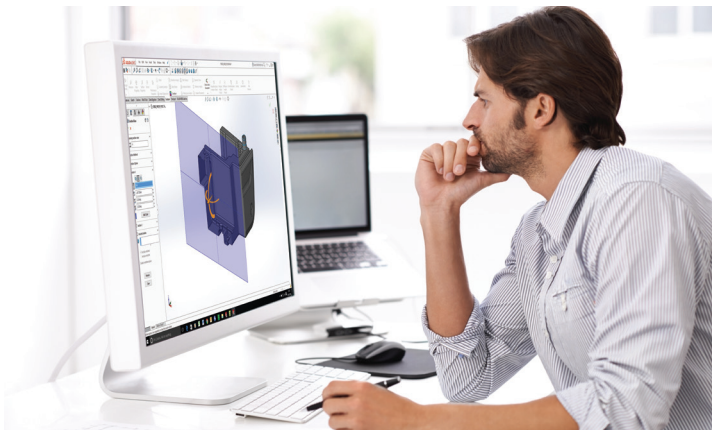

[kingspan.co.uk/klargester](http://kingspan.co.uk/klargester)



# Complete Wastewater and Surface Water Pumping Solutions

Benefiting from 68 years' experience, we offer a range of reliable wastewater and SuDS management solutions, along with expert service and maintenance.

Our tried and tested Kingspan Klargester product range includes sewage treatment plants, septic tanks, fuel and oil separators, pumping stations, grease traps and rainwater harvesting solutions.

In 2020, Kingspan launched Planet Passionate, our 10-year group wide global sustainability strategy which aims to impact on three big global issues: climate change, circularity and protection of our natural world.

2020 marked the first year of the journey and an array of key milestones were reached. Explore the milestones achieved, progress made and details on how our global business is stepping up to the challenging goals of our sustainability programme, all portrayed in our global, interactive Planet Passionate Annual Report.

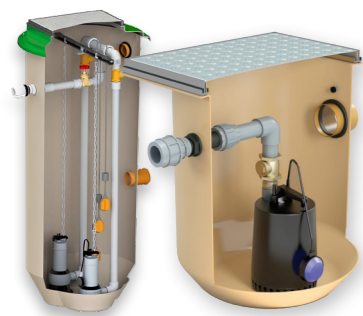

Effluent & Sewage Pumping Stations

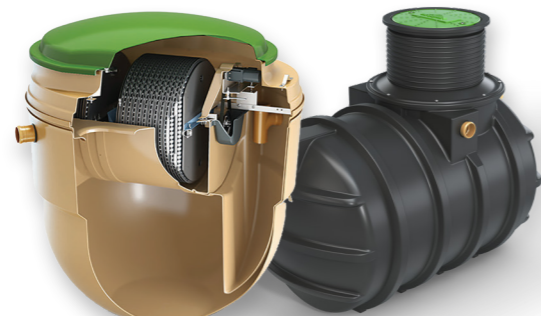

Sewage Treatment Plants

# Klargester Pumping Station Solutions

Experience

68 YEARS

Trusted wastewater treatment solutions across a wide range of domestic and commercial applications.



Typical Grundfos Pump

## The Trusted Water Management Experts

### About Kingspan

Kingspan have been leading specialists in the design and manufacture of an industry leading range of complete offmains wastewater management solutions for more than 68 years. Our dedicated technical team works closely with regulatory authorities and industry bodies to ensure total compliance in every component design and installation practice.

Providing solutions for all types of domestic, commercial or industrial build projects, the well-respected Klargester product range, includes sewage treatment plants, oil/water separators, packaged pumping stations and rainwater harvesting solutions.

### Klargester Pumping Stations

If your domestic or commercial property is not connected to the sewer, or if it is below the sewer line, our range of Klargester pumping stations will take care of all your water, sewage and effluent.

The quality of our pumping station solutions is further enhanced by incorporating pumps supplied by Grundfos, the world's largest dedicated pump manufacturer. The Grundfos wastewater pumps used in Kingspan products form part of a range that are all made with sustainability, long life and customer value at their core.

For expert advice, contact:  
**Email:** [klargest@kingspan.com](mailto:klargest@kingspan.com)  
**Tel:** 01296 633 033

## Why choose a Klargester Pumping Station solution?

Reliable, efficient, high quality pumping stations solutions.

Installed in thousands of domestic and commercial applications, the range of Klargester pumping stations provide easy to install and economical pumping solutions.

They are used in connection with sewage treatment plants, septic tanks, rainwater harvesting systems and surface water attenuation.

They are made with the highest quality materials and fittings and all are manufactured under the quality procedures of BS ISO 9001:2000 and HS ISO 18001, require little or no maintenance and, importantly, comply with Building Regulations Document H1 Foul Drainage and British Standards BS EN752, including options for 24-hour waste storage.

Fully Compliant



This product guide provides an overview of the solutions available and we are here to help in guiding you through the decision making process. Just get in touch to arrange a FREE site survey or to discuss your requirements in more detail with our technical experts, simply call 01296 633 033.

FREE SITE SURVEYS  
01296 633 033

## After Sales Service and Support.

We recognise the importance of after sales service and support and are proud of our nationwide Kingspan Service network, which comprises our Kingspan in-house Service team and Accredited Installer network in support of the Klargester Product Range.

With expertise across the entire Klargester product range, our local support networks provide the highest standards of after sales service and support you would expect from a global organisation including:

- First class technical engineering advice.
- Day to day technical support.
- 24 hour breakdown repair.
- Preventative maintenance plans.
- Installation and commissioning.
- Asset monitoring.
- Consultancy and advice.

For enquiries about any aspect of installation, commissioning or service simply contact:

**Tel:** 0333 240 6868

**Email:** [helpingyou@kingspan.com](mailto:helpingyou@kingspan.com)



Expert Technical Advice

## Typical Applications for Klargester Pumping Stations

### Applications for Domestic Pumping Stations Range:

From basements to caravans, extensions to courtyards. If your property isn't connected to the sewer, or if it's below the sewer line, our pumping stations will take care of all your water, sewage and effluent.



### Applications for Commercial Pumping Stations Range:

Whether you run a pub, shop or hotel, our range of commercial pumping stations make it easy to manage your sewage and wastewater, safely and efficiently.

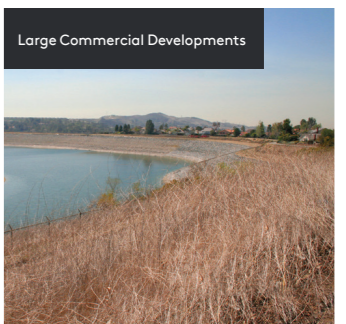
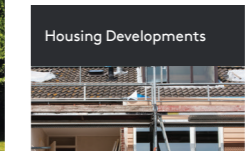
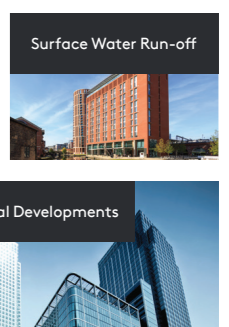
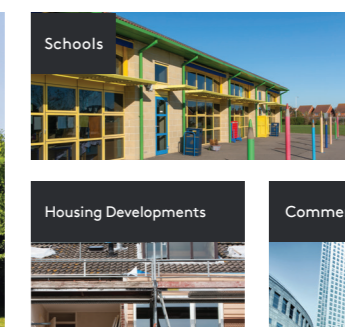

# Klargester AquaPump Compact Stations



Our proven range of compact pumping stations can be used for effluent or sewage and are easy to install.

Klargester compact pumping stations provide the perfect solution for managing effluent or sewage, depending on the pump, distance and height.

Quick and easy to install and maintain the compact range is ideal for use in outbuildings, extensions, cellars, pool houses and external WC applications.

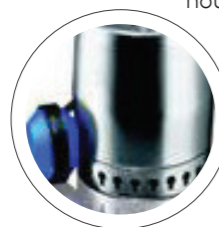

Typical Grundfos Unilift

### Product Benefits

- Non-return valves and outlet pipe compression coupling as standard.
- 3 pump options; effluent low head, effluent high head and sewage vortex.
- Service and maintenance plans available to prolong the life of the pump systems.
- Complete pre-fabricated solution ready for installation.
- Fully automatic.
- Robust, durable and corrosion free, stainless steel submersible Grundfos pumps.

Mini Pump Chamber - 200 Litre

Mini Pump Chamber - 400 Litre

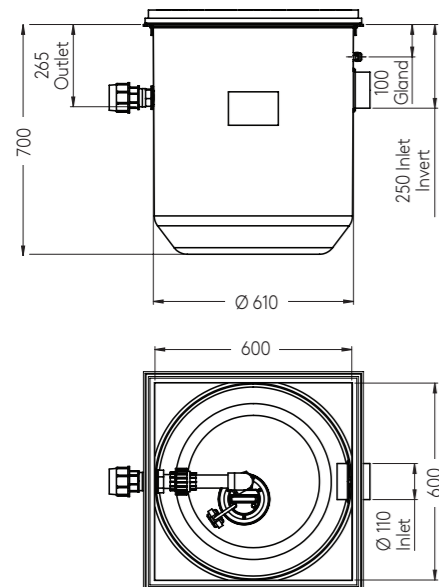

### Technical Specification

Chamber Size (mm)	Capacity (Ltrs)	Tank Material	Control Panel	Alarm	Pump Type
610 x 700	200	GRP	N/A	Optional	Single

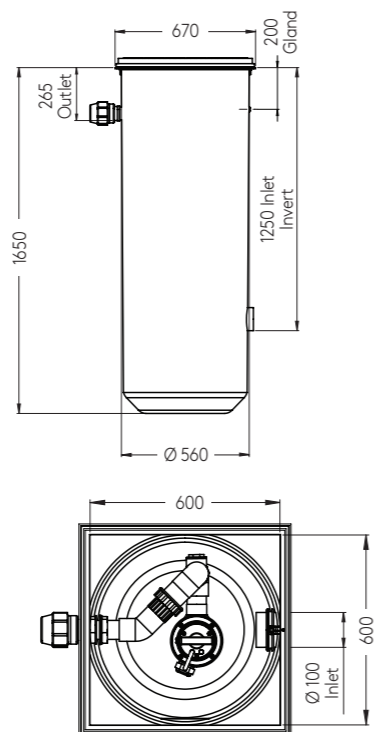

### Technical Specification

Chamber Size (mm)	Capacity (Ltrs)	Tank Material	Control Panel	Alarm	Pump Type
560 x 1,650	400	GRP	N/A	Optional	Single

# Klargester AquaPump - Domestic Stations



Our domestic pumping stations are ideal for homes or properties with up to 10 people.

Supplied with single or twin pumps, Klargester domestic pumping stations are suitable for sewage, surface water and effluent applications. They are also appropriate where 24 hour storage requirements need to be maintained.



Typical Grundfos AP Pump

### Product Benefits

- Made with super-tough, low maintenance GRP for guaranteed durability.
- Supplied with control panel with options for remote monitoring system.
- Designed with easy access features for maintenance.
- Choose from either 110mm or 160mm inlet connections.
- Lockable covers for optimum security.
- Quick connection outlet couplings.
- Reliable performing stainless steel submersible Grundfos pumps.

Domestic - GRP Construction

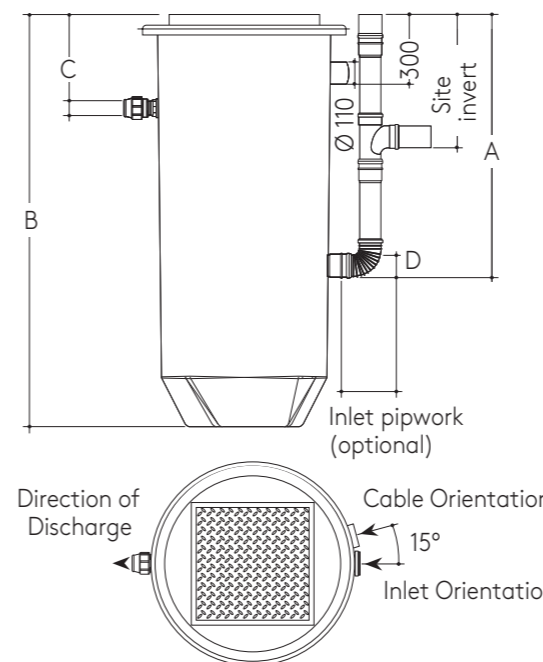

### Technical Specification

Chamber Size	Capacity	Tank Material	Control Panel	Alarm	Pump Type
900 x 1580	900	GRP	Included	Optional	Single/Twin
900 x 2160	1250	GRP	Included	Optional	Single/Twin
900 x 2670	1600	GRP	Included	Optional	Single/Twin

Case Diameter	Outlet Invert 'C'	Chamber Depth 'B'			Inlet Invert 'A' - Standard			Inlet Size 'D'
		Chamber A (2.16m)	Chamber B (2.67m)	Chamber E (1.58m)	Chamber A (1.3m)	Chamber B (1.8m)	Chamber E (0.7m)	
Ø900mm	535mm	•	•	•	•	•	•	Ø110mm or Ø160mm

# Klargester AquaPump - Vertical Stations



Klargester vertical pumping solutions are ideal for commercial developments and premises, where drainage by gravity is not an option.

Manufactured from robust GRP, Klargester vertical pumping stations are designed as a single-piece chamber, ready for installation with no man-entry required.

Available in a range of sizes and suitable for commercial applications from small roof run offs, to large SuDS schemes, Klargester vertical pumping stations deliver up to 70 litres/second and have a 24-hour storage capacity for foul waste to comply with Building Regulations.

### Product Benefits

- High-level alarm.
- Internal lifting chains and guide rails (as specified).
- Wide range of pump options including macerators/vortex.
- Range of emergency overflow tanks, if required.
- Inlet connection sizes to suit site.
- Various invert depths and positions.
- GRP chambers with internal pipework in plastic, galvanised or cast iron.
- Optional kiosks with warning beacons and optional telemetry systems.
- Service and maintenance plans available to prolong the life of the pump systems.
- Grundfos SL pump for submerged installation.

### Technical Specification

Vertical Tank Size (mm)	Capacity (Ltrs)	Tank Material	Control Panel	Alarm	Pump Type
1250 Diameter	Up to 4,800	GRP	Included	Standard	Single/Twin
1800 Diameter	Up to 10,000	GRP	Included	Standard	Single/Twin
2600 Diameter	Up to 22,000	GRP	Included	Standard	Single/Twin

Ø1.8

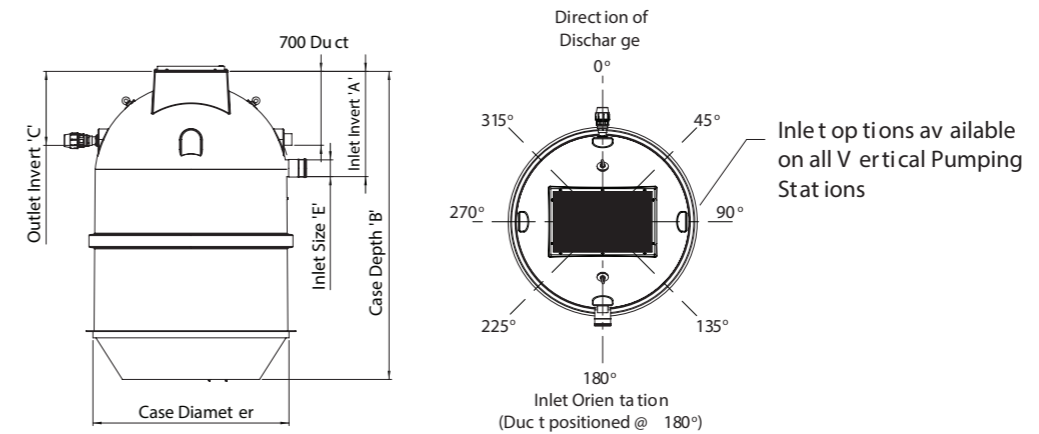

Case Diameter	Outlet Invert 'C'	Case Depth 'B'						Standard Inlet Invert 'A' - Others Available If Required Contact Technical Team						Inlet Size 'E'	
		20 (2.0m)	25 (2.5m)	30 (3.0m)	35 (3.5m)	40 (4.0m)	45 (4.5m)	10 (1.0m)	15 (1.5m)	20 (2.0m)	25 (2.5m)	30 (3.0m)	35 (3.5m)		
1.8m	0.7m														

Ø1.2

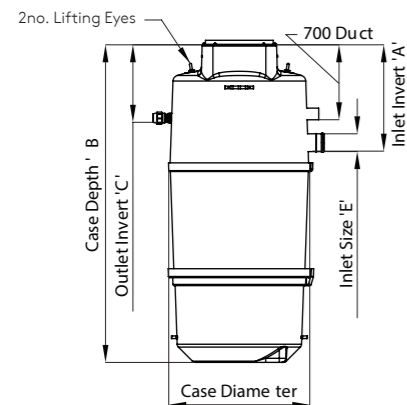

Full range of Grundfos Pumps available for all Vertical Pumping Stations

Case Diameter	Outlet Invert 'C'	Case Depth 'B'						Standard Inlet Invert 'A' - Others Available If Required Contact Technical Team						Inlet Size 'E'
		20 (2.0m)	25 (2.5m)	30 (3.0m)	35 (3.5m)	40 (4.0m)	10 (1.0m)	15 (1.5m)	20 (2.0m)	25 (2.5m)	30 (3.0m)			
1.25m	0.7m													

Ø2.6

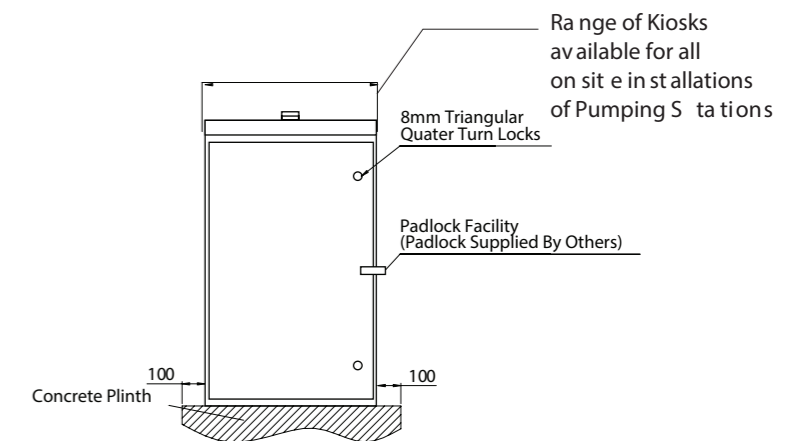
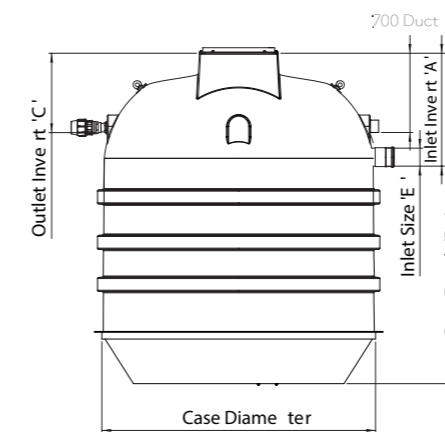

Case Diameter	Outlet Invert 'C'	Case Depth 'B'			Standard Inlet Invert 'A' - Others Available If Required Contact Technical Team						Inlet Size 'E'	
		33 (3.3m)	40 (4.0m)	45 (4.5m)	10 (1.0m)	15 (1.5m)	20 (2.0m)	25 (2.5m)	30 (3.0m)	35 (3.5m)		
2.6m	0.7m											

# Klargester AquaPump - Horizontal Stations

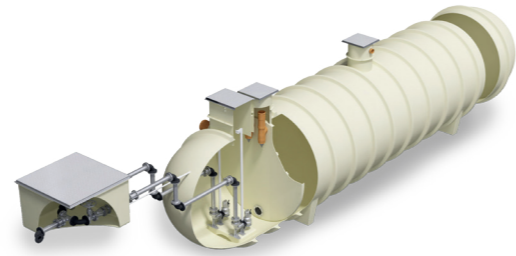

If power supplies fail, Klargester horizontal pumping stations respond instantly, separating liquids and solids into a separate chamber, storing waste for up to 24 hours. Once power is restored, the pumps will work normally again without further maintenance.

### Product Benefits

- Single-tank installation up to 79m<sup>3</sup> (multiple tank systems available).
- Multiple valve chamber location and invert options.
- Weir screen features innovative removable filters, so there's no need to access the chamber during maintenance.
- High-level alarm.
- Totally sealed system.
- One-piece tank chamber for easy installation.
- Minimal on-site assembly.
- Less craning and shallower excavation than concrete pumping stations.
- On-site Health & Safety issues are minimised – no requirement for personnel to enter the tank.
- Grundfos industrial pump for high capacity submerged installation.

Klargester horizontal pumping stations are designed as a single piece chamber with two separate sections - one for normal operation and one for emergency storage.

Typical Grundfos Industrial Pump

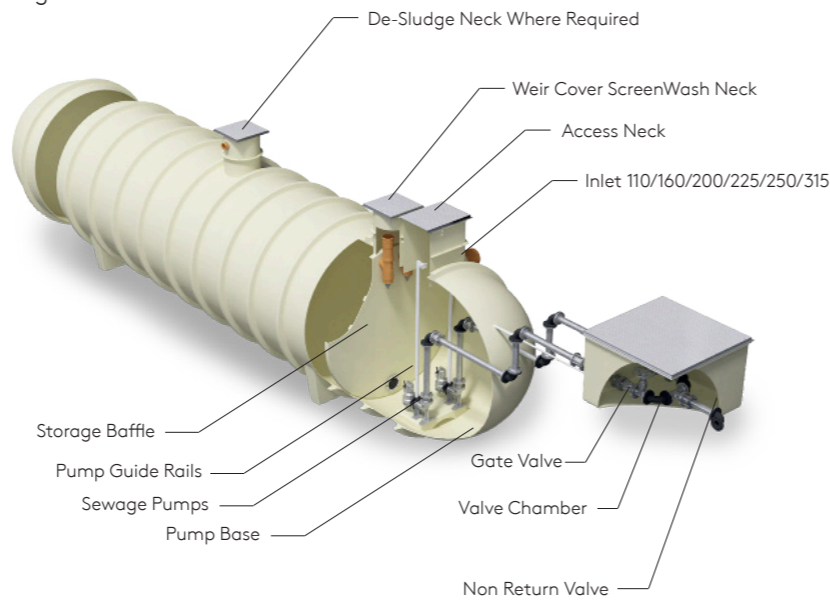
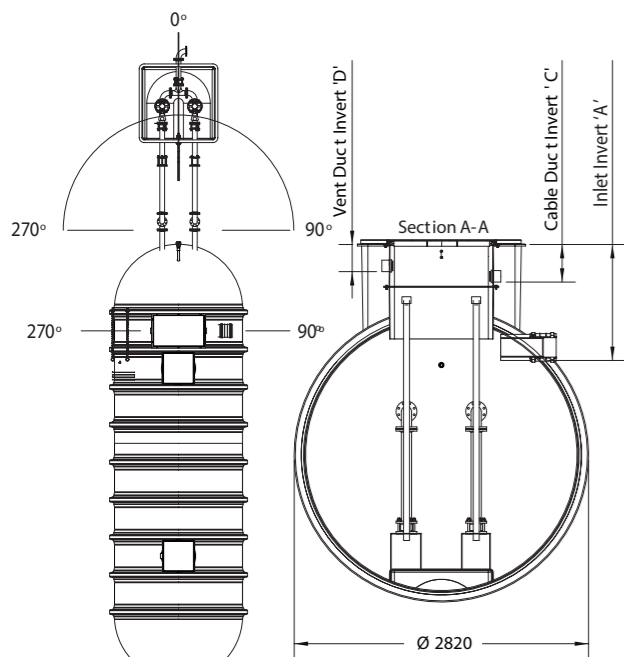

### Technical Specification

Tank Size (mm)	Capacity (Ltrs)	Tank Material	Control Panel	Alarm	Pump Type
2,600 Diameter	18000-79000	GRP	Included	Standard	Single/Twin

# Klargester AquaPump - Adoptable and High Specification Stations

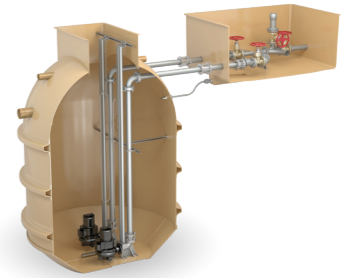

The adoptable and high specification pumping stations are designed to meet the requirements of 'Sewers for Adoption 7th Edition' and the 'Water Industry Standard' (WIS). They also meet NI Water Standard Specification (May 2016).

### Product Benefits

- GRP single piece wet well delivered to site ready to install.
- Pre-fitted internal pipework, pump guide rails and overflow filters.
- Approved control panel and kiosk.
- All necessary drawings supplied.
- NI Water specified Controls and Hygiene unit.
- Grundfos pumps for submerged installation.

Manufactured as a ready to install single piece, prefabricated unit for Type 1 and Type 2 installations for up to 20 dwellings, please contact our specialist team for further advice on this high specification product.

Typical Grundfos SL Pump



### Typical Layout

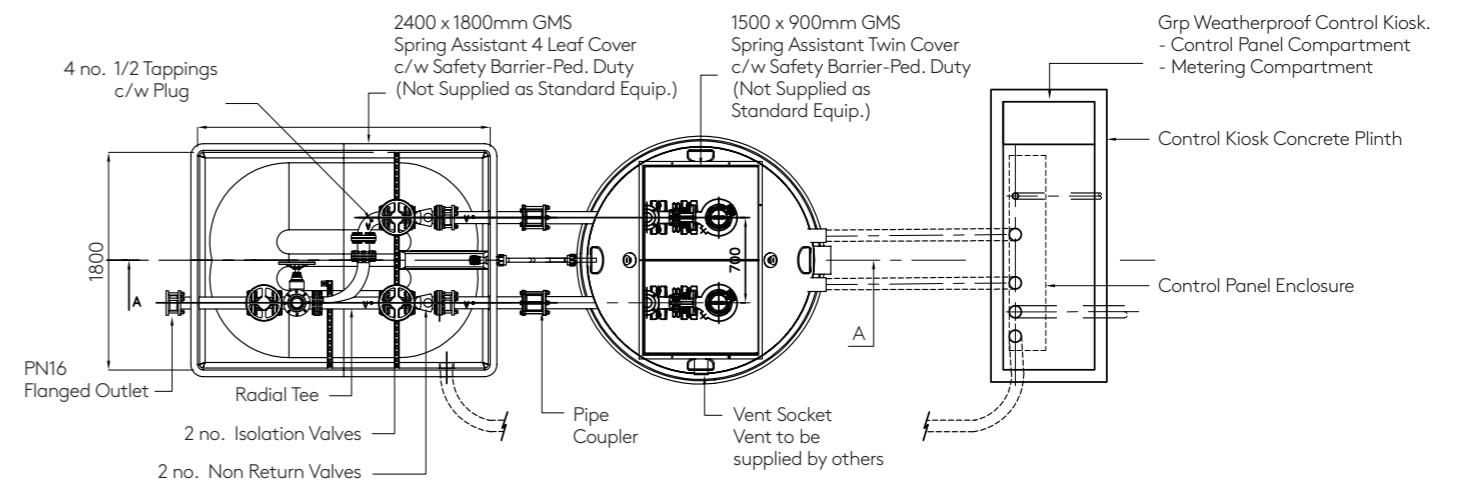

# Selecting the Correct Pumping Station

Free expert advice at every stage.

All Klargester pumping stations are suitable for pumping wastewater effluent and sewage in accordance with BS 756-2. They are also designed in line with Building Regulations for Foul Drainage.

System size requirements will depend on the type of waste you need to manage, distance from the sewer and the difference in levels.

The Klargester pumping station range will require less crange and shallower excavations than concrete pumping systems and there is no need for anyone to enter the tank during excavation and installation.

Prior to installation, there is a legal requirement to obtain permission from the appropriate agencies (including connection to a public sewer).

For expert advice, to help you select the correct system, please contact our specialist team on **01296 633 033** or email [klargest@kingspan.com](mailto:klargest@kingspan.com)

**The key factors to size your system are as follows:**

- Application: domestic, residential or commercial
- Material application: sewage, effluent or surface water.
- Inlet depth (below ground level).
- Pumping distance and lift.
- Electrical supply.



# Sizing Chart

Measurement

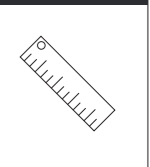

Please use the chart below to help correctly size and select your Klargester Pumping Station solution.

Pumping Distance (A)		Meters
Pumping Lift (B)		Meters
Discharge Height (C) (if different to Lift)		Meters
Proposed Inlet Depth (D)		Meters
Inlet Size	110mm <input type="checkbox"/> 160mm <input type="checkbox"/>	
Type of Application ie. 1 House, 2 Houses , pub, etc		
Number of Users		
Material Application	Sewage <input type="checkbox"/> Surface Water <input type="checkbox"/> Effluent <input type="checkbox"/>	
	Flow rate* (if known): <input type="text"/>	
	Drainage area* (if known): <input type="text"/>	
	<small>*Only applicable to Surface Water</small>	
Power Supply	Single <input type="checkbox"/> Three Phase <input type="checkbox"/>	
New Lay or Existing Rising Main	New <input type="checkbox"/> Existing <input type="checkbox"/>	
If Existing - Size of Rising Main		
Pumping to: Public/Private Sewer, Treatment Plant, etc.		
24 Hours Storage Required	Yes <input type="checkbox"/> No <input type="checkbox"/>	



---

## UK

### Kingspan Water & Energy Ltd

College Road North,  
Aston Clinton, Aylesbury,  
Buckinghamshire, HP22 5EW

T: 01296 633 033

F: +44 (0) 1296 633001

E: [Klargester@Kingspan.com](mailto:Klargester@Kingspan.com)

W: [kingspan.co.uk/klargester](http://kingspan.co.uk/klargester)

We take every care and precaution to ensure that information in this document is accurate at the point of publish but with continuous product development the details given in this document are subject to alteration without notice.

Kingspan | Klargester Product Guide – English GB – C23.9326

