

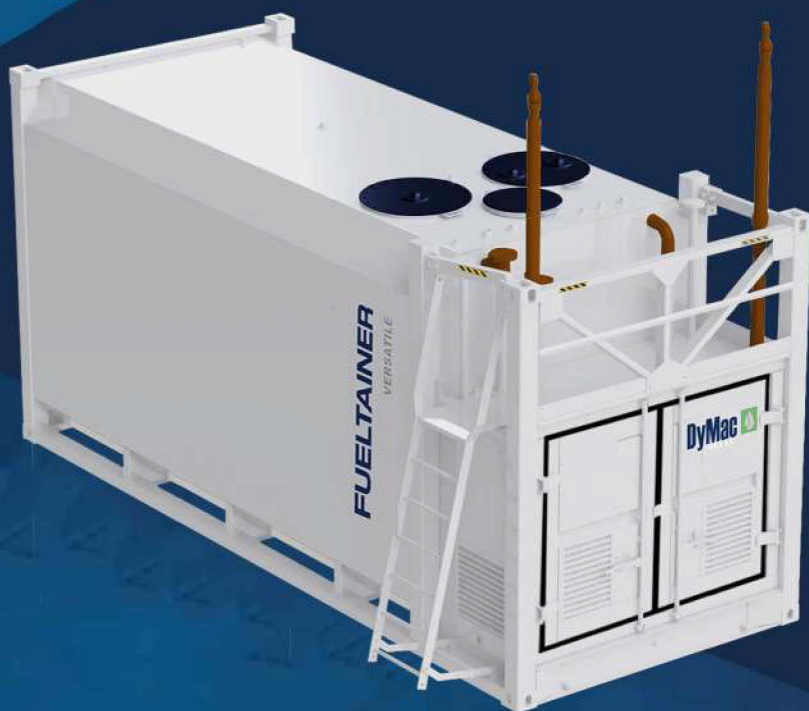

The FuelTainer versatile range come complete with ISO, CSC & UL142 approvals and are a containerised tank design

Available Sizes

- ✓ FTV-12000L/3128G
- ✓ FTV-17000L/4491G
- ✓ FTV-30900L/8163G
- ✓ FTV-38000L/10039G
- ✓ FTV-68000L/18234G
- ✓ FTV-75000L/19813G



FUELTAINER
versatile

DyMac Global Head Office | Kitsmead Lane | Longcross | Chertsey | Surrey UK | KT16 0EF
+44 300 303 3353 | sales@dymacglobal.com | www.dymacglobal.com



FUELTAINER

VERSATILE

Enhanced Design Features

Unique Design Standard

The FuelTainer Versatile Bunded Tank with its rectangle shape is an innovative unique tank design and has become the go-to bulk fuel storage tank solution for industry leaders world wide.

Maintenance & Environment

To ensure efficient cleaning and maintenance can take place the tanks have been designed with manway cover lids and an internal integrated ladder system allowing easy access inside the tank to reach the inner tank floors. This innovative design allows flexible inspections top take place and insures a minimal amount of downtime.

Dispensing & Accessibility

The FuelTainer versatile Tank comes equipped with a spacious secure equipment compartment area which can house various dispensing pumps and fuel and management systems. It comes with over-head pylons and integrated dispensing hoses & nozzles, allowing the bulk tank to work as a safew and secure independent stand alone fuel station.

Transportable & Portable

All FuelTainer versatile tanks have been designed to be easily transported when empty. They come with there own ISO twist locks allowing them to be fixed onto 40ft flat bed trucks and transported over long distances by road.



Proven Design

Take a look inside

The Class leading FuelTainer versatile tank range is an ISO,CSC double wall tank design, featuring a fully integrated 6mm inner tank and a 6mm outer protection tank. The range comprises large double cargo doors which open up to a large equipment compartment area allowing the easy up-fitting of various pumps, reels ,flow meters, filters, dispensing equipment and Fuel management systems. Designed as static tanks they are portable when empty and are suited to many fuel and fluid applications world wide.

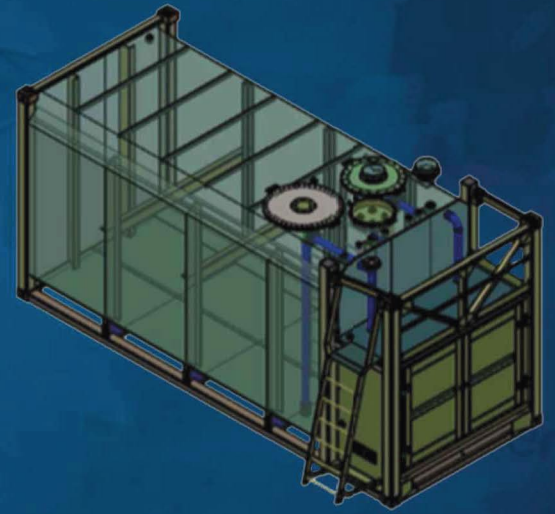

Superior Features

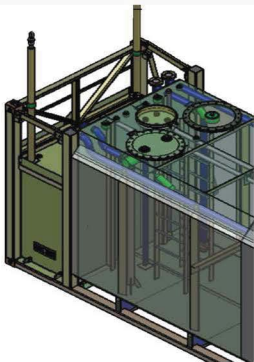

Multiple Ports fittings and Down pipes designed to accommodate various applications

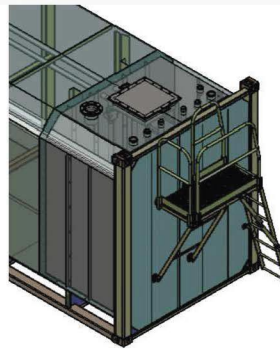

Collapsible ladder and walkway design for ease while in transit.

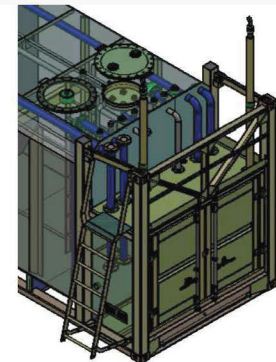

Large double container doors securing an extra large equipment compartment area.

Optional Accessories



Fuel and Fluid Dispensing Nozzle and Flow Meter Console Options.



Spill Control Floor with Bracket system and retractable hose reel Options.

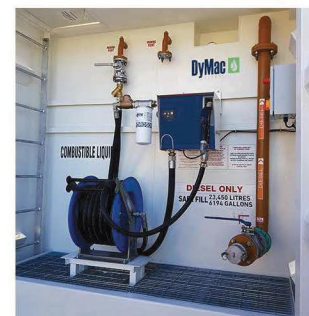

Filter Options that offer the removal of sediment, scale, rust and water particles from Diesel.

FUELTAINER

VERSATILE

Model (FTV-30900L / 8163G)

The FuelTainer versatile tank is a class leading innovative double wall tank design that provides the safe and secure storage and dispensing of fuels & fluids. The tank can be easily up-fitted with various Pumps, reels, flow meters, filters & dispensing systems.



Specifications

	Metric	US	Imperial
Capacity	30901 Litres	8163 Gallons	6797 Gallons
Length	6058 mm	238"	238"
Width	2438 mm	95 15/16"	95 15/16"
Height	2896 mm	114"	114"
Bund Tank Material	4 mm	2/16"	2/16"
Inner Tank Material	6 mm	3/16"	3/16"
Mass(empty)	7837 kg	17277 lbs, 10oz	1727 lbs, 10oz
Mass(full)	34252 kg	75512 lbs, 10oz	75512 lbs, 10oz
Safe Fill Level	29350 Litres	7753 Gallons	6456 Gallons

Approvals and Certifications

UK & Europe

- ✓ Lifting when Empty
- ✓ UL142
- ✓ ULC S601
- ✓ CSC
- ✓ ISO688
- ✓ AS1940
- ✓ AS1692 CAT. 3
- Optional
- ✓ BS799

USA & Canada

- ✓ Lifting when Empty
- ✓ UL142
- ✓ ULC S601
- ✓ CSC
- ✓ ISO688

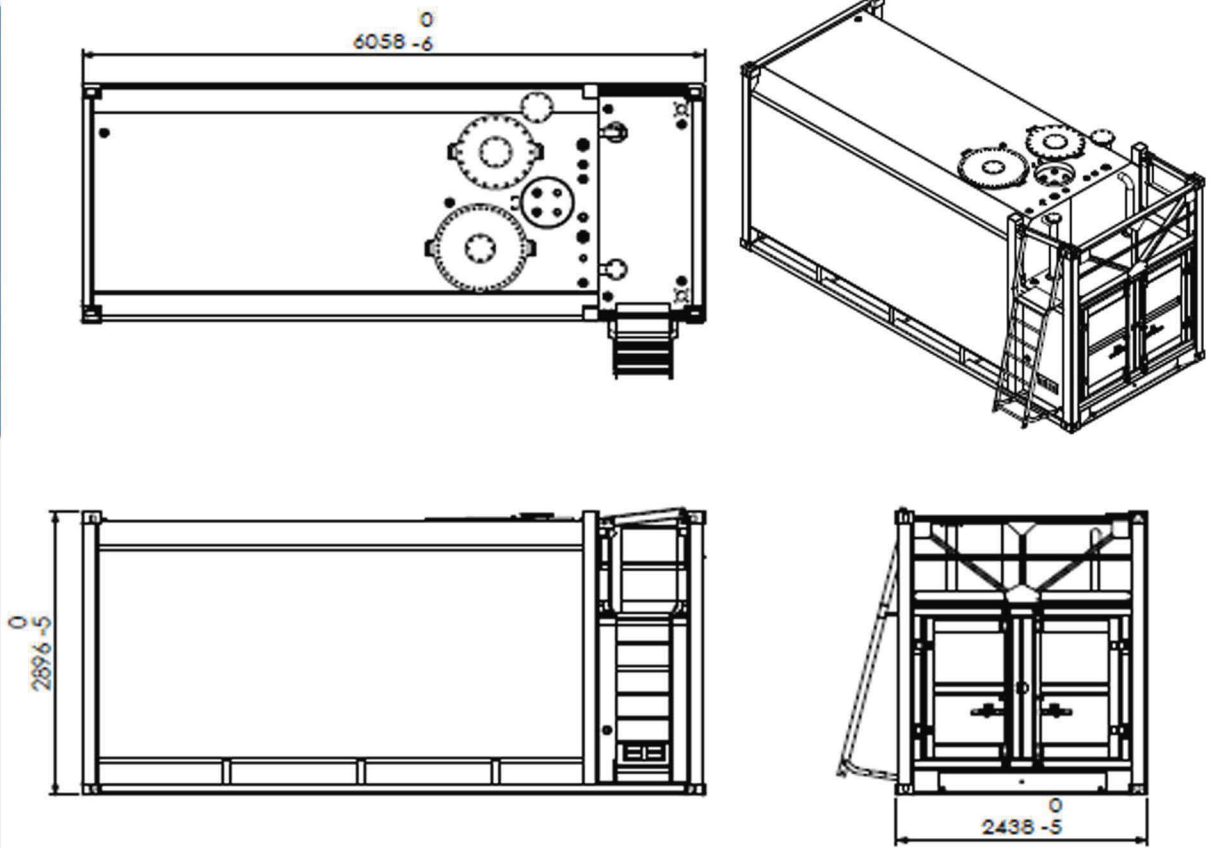

The FuelTainer versatile tank features a large equipment compartment area designed to host various Pumps, Dispensing Stations and STPs brands. Examples shown in the exploded images below.

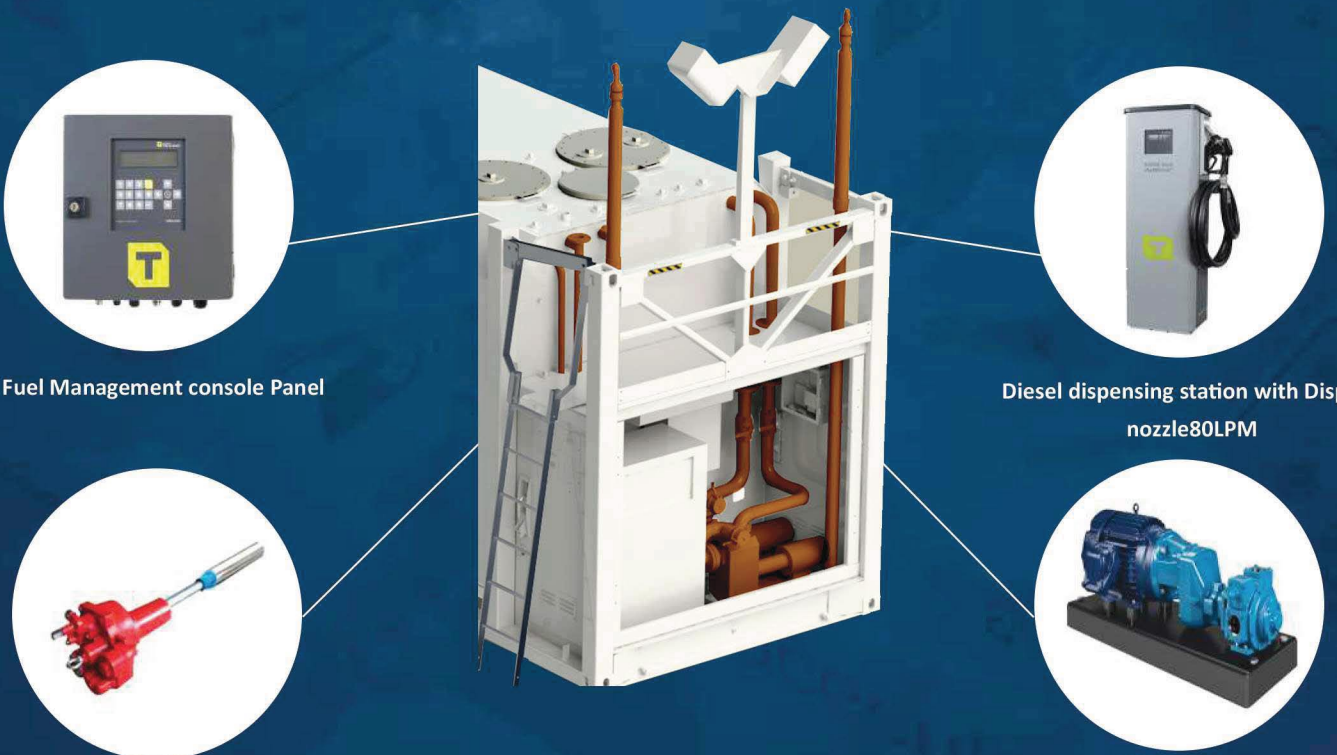

Fuel Management console Panel

Diesel dispensing station with Dispensing nozzle 80LPM

Red Jacket Submersible Turbine Pump

Blackmer GNX Series pumps provides flow capacities from 7 to 500 gpm (25 to 1,893 L/min)

FUELTAINER

VERSATILE

Model (FTV-68000L / 18234G)

The FuelTainer versatile tank is a class leading innovative double wall tank design that provides the safe and secure storage and dispensing of fuels & fluids. The tank can be easily up-fitted with various Pumps, reels, flow meters, filters & dispensing systems.



Specifications

	Metric	US	Imperial
Capacity	69023 Litres	18234 Gallons	15183 Gallons
Length	12192 mm	480"	480"
Width	2438 mm	95 15/16"	95 15/16"
Height	2896 mm	114"	114"
Bund Tank Material	4 mm	2/16"	2/16"
Inner Tank Material	6 mm	3/16"	3/16"
Mass(empty)	13459 kg	29672 lbs, 10oz	29672 lbs, 10oz
Mass(full)	72652 kg	160170 lbs, 10oz	160170 lbs, 10oz
Safe Fill Level	65770 Litres	17375 Gallons	14467 Gallons

Approvals and Certifications

UK & Europe

- ✓ Lifting when Empty
- ✓ UL142
- ✓ ULC S601
- ✓ CSC
- ✓ ISO688
- ✓ AS1940
- ✓ AS1692 CAT. 3
- Optional
- ✓ BS799

USA & Canada

- ✓ Lifting when Empty
- ✓ UL142
- ✓ ULC S601
- ✓ CSC
- ✓ ISO688

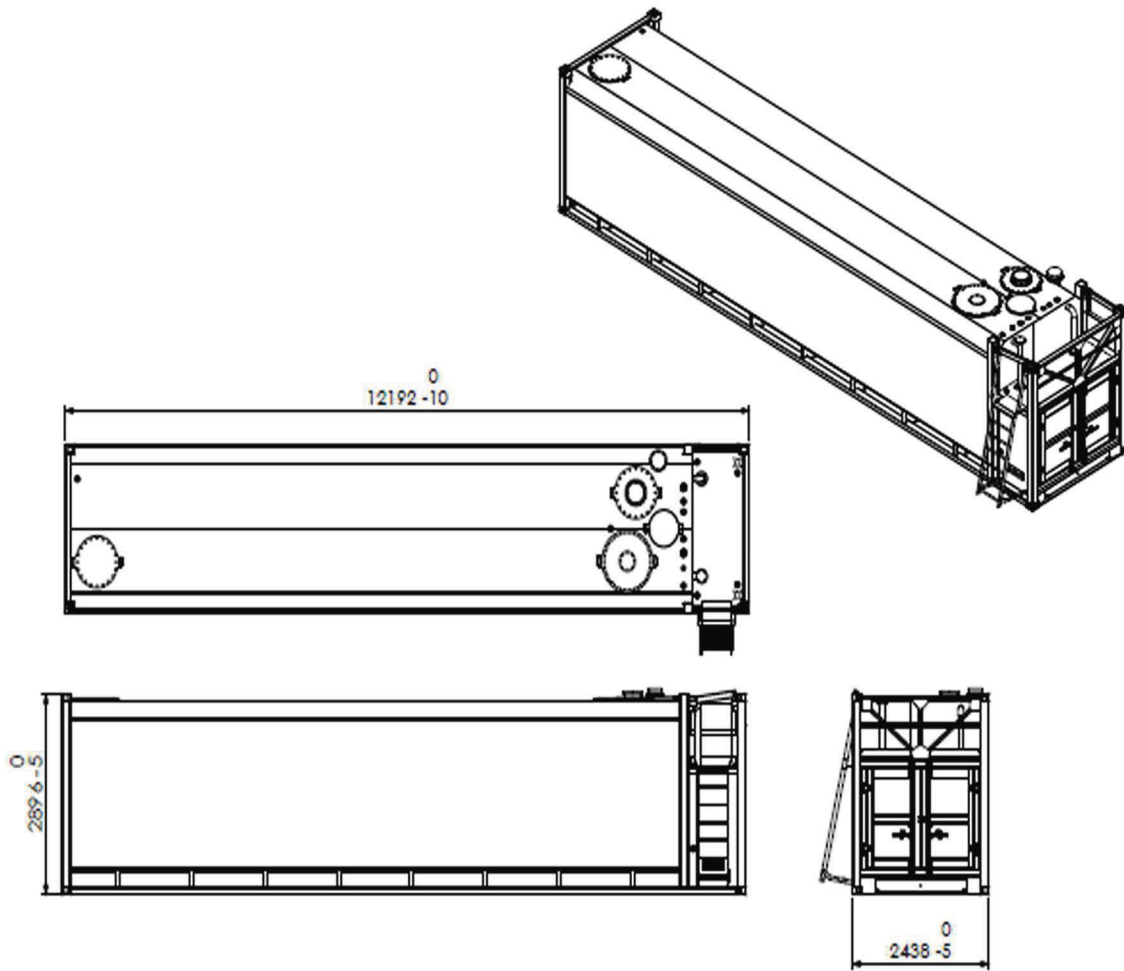

The FuelTainer versatile tank features a large equipment compartment area designed to host various Pumps, Dispensing Stations and STPs brands. Examples shown in the exploded images below.



Fuel Management console Panel



Diesel dispensing station with Dispensing nozzle80LPM



Red Jacket Submersible Turbine Pump



Blackmer GNX Series pumps provides flow capacities from 7 to 500 gpm (25 to 1,893 L/min)